



**POWER
HT +**

Installation and Service Manual

Gas fired floor-standing condensing boiler

POWER HT+ 1.50
POWER HT+ 1.70
POWER HT+ 1.90
POWER HT+ 1.110

Dear customer,

Thank you for purchasing this appliance.

Please read this manual carefully before using the product and keep it in a safe place for future reference.

In order to ensure continued safe and efficient operation we recommend that the product is regularly maintained. Our Service and After Sales organization can assist with this.

We hope you will receive many years of satisfactory service.

Contents

1	Safety	6
1.1	General safety instructions	6
1.2	Recommendations	7
1.3	Liabilities	8
1.3.1	Manufacturer's liability	8
1.3.2	Installer's liability	9
2	About this manual	10
2.1	General	10
2.2	Symbols used	10
2.2.1	Symbols used in the manual	10
2.2.2	Symbols used on the appliance	10
3	Technical specifications	11
3.1	Homologations	11
3.1.1	Directives	11
3.1.2	Ecodesign Directive	11
3.1.3	Certifications	11
3.2	Technical data	11
3.2.1	Other technical parameters	13
3.2.2	Sensor specifications	13
3.3	Dimensions and connections	14
3.4	Electrical diagram	16
4	Description of the product	18
4.1	General description	18
4.2	Operating principle	18
4.2.1	Circulation pump	18
4.2.2	Gas/air setting	18
4.2.3	Low-loss header (accessory)	18
4.2.4	System in cascade	19
4.2.5	Settings and safety devices	20
4.3	Main components	21
4.4	Control panel description	22
4.4.1	Description of the keys	22
4.4.2	Description of the symbols	22
4.5	Standard delivery	23
4.6	Accessories and options	23
5	Before installation	24
5.1	Installation regulations	24
5.2	Installation requirements	24
5.2.1	Water treatment	24
5.2.2	Gas supply	25
5.2.3	Electrical power supply	25
5.2.4	Circulating pump	25
5.3	Choice of the location	26
5.3.1	Ventilation	27
5.3.2	Overall space needed for the boiler	27
5.3.3	Data plate	28
5.3.4	Selecting the position for the outside temperature sensor (optional)	29
5.4	Transport	30
5.5	Unpacking and initial preparation	30
5.6	Connecting diagrams	31
5.6.1	Connection diagram: 1 boiler + 1 direct circuit + 1 domestic hot water tank	31
5.6.2	Connection diagram: 1 boiler + 1 direct circuit + 1 underfloor heating circuit + 1 domestic hot water tank	32
5.6.3	Connection diagram: Boilers in cascade + 1 direct circuit + 1 underfloor heating circuit + 1 domestic hot water tank	33
5.6.4	Connection diagram: controlling a boiler in 0-10 V	34
6	Installation	35
6.1	General	35

6.2	Preparation	35
6.2.1	Accessing the internal boiler components	35
6.3	Water connections	37
6.3.1	Connection of the heating circuit	37
6.3.2	Connecting the expansion vessel	38
6.3.3	Connecting the condensate discharge pipe	39
6.4	Gas connection	39
6.5	Air supply/flue gas connections	40
6.5.1	Classification	40
6.5.2	Coaxial pipes	41
6.5.3	Pipes in cascade (not provided)	42
6.5.4	Lengths of the air/flue gas pipes	42
6.6	Electrical connections	45
6.6.1	Recommendations	45
6.6.2	Recommended cable cross section	45
6.6.3	Accessing the terminal blocks	45
6.6.4	Wiring the terminal blocks	45
6.6.5	Description of the power supply terminal block	47
6.6.6	Description of the sensor terminal block	48
6.6.7	Electrical connection: 1 boiler + 1 direct circuit + 1 domestic hot water tank	49
6.6.8	Electrical connection: 1 boiler + 1 direct circuit + 1 underfloor heating circuit + 1 domestic hot water tank	49
6.6.9	Electrical connection: controlling a boiler in 0-10 V	50
6.6.10	Electrical connection: Boilers in cascade + 1 direct circuit + 1 underfloor heating circuit + 1 domestic hot water tank	51
6.6.11	Connecting boilers in cascade with a module OCI 345	52
6.7	Filling the system	52
6.7.1	Filling the heating system	52
6.7.2	Filling the siphon	53
6.8	Completing installation	53
7	Commissioning	54
7.1	General	54
7.2	Check-list before commissioning	54
7.3	Commissioning procedure	54
7.3.1	First time commissioning	54
7.3.2	Checking the gas inlet	54
7.3.3	Checking the electrical connections	55
7.3.4	Checking the hydraulic circuit	55
7.4	Configuring the system	55
7.4.1	Configuring an installation with 1 boiler + 1 low-loss header + 1 direct circuit + 1 underfloor heating circuit + 1 domestic hot water tank	55
7.4.2	Configuring boilers in cascade + 1 direct circuit + 1 underfloor heating circuit + 1 domestic hot water tank	55
7.4.3	Configuring control of a boiler in 0-10 V	56
7.4.4	Configuring a master boiler and the slave boilers in a cascade	57
8	Operation	58
8.1	Use of the control panel	58
8.1.1	Modifying the user parameters	58
8.1.2	Modifying the installer parameters	58
8.2	Starting up the boiler	59
8.3	Stopping the boiler	59
8.3.1	Putting the boiler in Standby mode	59
8.4	Frost Protection	60
8.4.1	Activating the Off	60
9	Settings	61
9.1	List of parameters	61
9.1.1	Shortcuts menu	61
9.1.2	Information menu	61
9.1.3	List of user parameters	62
9.1.4	List of installer parameters	64
9.2	Setting the parameters	75
9.2.1	Setting the date and time	75
9.2.2	Language Selection	76
9.2.3	Changing the operating mode	77

9.2.4	Forcing domestic hot water production	78
9.2.5	Setting the room temperature set point (Onmode)	78
9.2.6	Modifying the domestic hot water production mode	79
9.2.7	Setting the domestic hot water temperature set point	79
9.2.8	Setting the room temperature set point (Reduced mode)	80
9.2.9	Programming a Holiday period	81
9.2.10	Using the boiler according to thermal output	84
9.2.11	Selecting a heating circuit	85
9.2.12	Locking / Unlocking parameter modification	85
9.2.13	Timer program	87
9.2.14	Setting a temporary heating flow temperature	95
9.2.15	Managing boilers in cascade	95
9.3	Accessing the information menu	95
10	Maintenance	97
10.1	General	97
10.2	Standard inspection and maintenance operations	97
10.2.1	Performing the annual service	97
10.2.2	Removing the burner	97
10.2.3	Cleaning the heat exchanger	100
10.2.4	Checking the burner	100
10.2.5	Cleaning the siphon	102
10.2.6	Remounting the burner	102
10.2.7	Thermal fuse in the heat exchanger	103
10.2.8	Check the combustion	104
10.3	Replacing the 4 A fuses on the electrical terminal blocks	107
11	Troubleshooting	109
11.1	Error codes	109
11.1.1	Automatic error code clearing	110
11.1.2	Clearing error codes	111
12	Decommissioning	112
12.1	Decommissioning procedure	112
12.2	Recommissioning procedure	112
13	Disposal/recycling	113
13.1	Disposal and Recycling	113
14	Appendix	114
14.1	EC Declaration of Conformity	114

1 Safety

1.1 General safety instructions



Danger

This appliance can be used by children aged from 8 years and above and persons with reduced physical, sensory or mental capabilities or lack of experience and knowledge if they have been given supervision or instruction concerning use of the appliance in a safe way and understand the hazards involved. Children shall not play with the appliance. Cleaning and user maintenance shall not be made by children without supervision.



Danger

If you smell gas:

1. Do not use a naked flame, do not smoke, do not operate electrical contacts or switches (doorbell, light, motor, lift, etc.).
2. Shut off the gas supply.
3. Open the windows.
4. Trace possible leaks and seal them immediately.
5. If the gas leak is before the gas meter, contact the gas supplier.



Danger

If you smell flue gases:

1. Switch off the appliance.
2. Open the windows.
3. Trace possible leaks and seal them immediately.



Warning

Do not touch the flue gas pipes. Depending on the boiler settings, the temperature of the flue gas pipes may exceed 60°C.



Warning

Do not touch the radiators for long periods. Depending on the boiler settings, the temperature of the radiators may exceed 60°C.



Warning

Take precautions with the domestic hot water. Depending on the boiler settings, the domestic hot water temperature may exceed 65°C.





Danger of electric shock

Before any work, switch off the mains supply to the boiler.

1.2 Recommendations

 **Note**
Keep this document close to the place where the appliance is installed.

 **Note**
Never remove or cover labels and data plates affixed to the appliances. Labels and data plates must be legible throughout the entire lifetime of the appliance. Immediately replace damaged or illegible instructions and warning stickers.

 **Caution**
The appliance should be on Summer or Antifreeze mode rather than switched off to guarantee the following functions:

- Anti-blocking of pumps
- Frost Protection

 **Caution**
If the home is unoccupied for a long period and there is a risk of frost, drain the boiler and the heating system.

 **Caution**
To enjoy warranty cover, no modifications must be made to the appliance.

 **Caution**
The frost protection does not work if the boiler is switched off.

 **Caution**
The integrated protection system only protects the boiler, not the heating installation

 **Caution**
Remove the boiler casing only to perform maintenance and repair work. Always put the casing back in place after such work.

 **Warning**
Only qualified professionals are authorised to work on the boiler and the heating installation.

 **Note**
Keep the boiler accessible at all times.

 **Caution**
Installation of the boiler must be done by a qualified professional in accordance with prevailing local and national regulations.

 **Caution**
Install the boiler in a frost-free location.



Caution

Do not stock chloride or fluoride compounds close to the boiler. They are particularly corrosive and may contaminate the combustive air. Chloride and fluoride compounds are present in aerosol sprays, paints, solvents, cleaning products, washing products, detergents, glues, snow clearing salts.



Caution

Do not neglect to service the boiler. Contact a qualified professional or subscribe to a maintenance contract for the annual servicing of the boiler.



Note

Regularly check the presence of water and pressure in the heating installation.



Caution

Maintenance work must be carried out by a qualified professional.



Caution

Only a qualified professional is authorised to clean the inside of the boiler.



Caution

Only genuine spare parts may be used.



Caution

After maintenance or repair work, check the entire heating installation to ensure that there are no leaks.



Warning

- Ensure correct earthing.
- Install the appliance on a solid, stable structure able to bear its weight.



Warning

Removal and disposal of the boiler must be carried out by a qualified installer in accordance with local and national regulations



Caution

If the power cord is damaged, it must be replaced by the manufacturer, its after sales service or persons with similar qualifications in order to obviate any danger.

1.3 Liabilities

1.3.1 Manufacturer's liability

Our products are manufactured in compliance with the requirements of the various Directives applicable. They are therefore delivered with the CE marking and any documents necessary. In the interests of the quality of our products, we

strive constantly to improve them. We therefore reserve the right to modify the specifications given in this document.

Our liability as manufacturer may not be invoked in the following cases:

- Failure to abide by the instructions on installing the appliance.
- Failure to abide by the instructions on using the appliance.
- Faulty or insufficient maintenance of the appliance.

1.3.2 Installer's liability

The installer is responsible for the installation and initial commissioning of the appliance. The installer must abide by the following instructions:

- Read and follow the instructions given in the manuals provided with the appliance.
- Install the appliance in compliance with prevailing legislation and standards.
- Carry out initial commissioning and any checks necessary.
- Explain the installation to the user.
- If maintenance is necessary, warn the user of the obligation to check the appliance and keep it in good working order.
- Give all the instruction manuals to the user.

2 About this manual

2.1 General

This manual is intended for the installer of a POWER HT + heat pump.

2.2 Symbols used

2.2.1 Symbols used in the manual

This manual uses various danger levels to draw attention to special instructions. We do this to improve user safety, to prevent problems and to guarantee correct operation of the appliance.



Danger

Risk of dangerous situations that may result in serious personal injury.



Danger of electric shock

Risk of electric shock.



Warning

Risk of dangerous situations that may result in minor personal injury.



Caution

Risk of material damage.



Note

Please note: important information.



See

Reference to other manuals or pages in this manual.

2.2.2 Symbols used on the appliance

- 1 Alternating current.
- 2 Protective earthing.
- 3 Before installing and commissioning the appliance, carefully read the instruction manuals provided.
- 4 Dispose of used products through an appropriate recovery and recycling structure.
- 5 Caution: danger of electric shock, live parts. Disconnect the mains power prior to carrying out any work.

Fig.1 Symbols used on the appliance

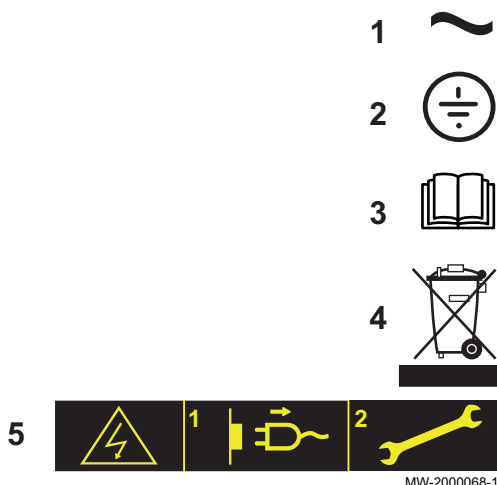

MW-2000068-1

3 Technical specifications

3.1 Homologations

3.1.1 Directives

This product has been manufactured and put into circulation in accordance with the requirements and standards of the following European Directives:

- Gas Directive 2009/142/EC
- Pressure Equipment Directive 97/23/EC, Article 3, paragraph 3
- Electromagnetic Compatibility Directive 2004/108/EC
Generic standards: EN 61000-6-3, EN 61000-6-1
Standard referred to: EN 55014
- Low Voltage Directive 2006/95/EC
Generic standard: EN 60335-1
Standard referred to: EN 60335-2-102
- Efficiency Directive 92/42/EC

Apart from the legal provisions and Directives, the additional Directives described in these instructions must also be observed.

For all provisions and Directives referred to in these instructions, it is agreed that all addenda or subsequent provisions will apply at the time of installation.

3.1.2 Ecodesign Directive

This product conforms to the requirements of European Directive 2009/125/EC on the ecodesign of energy-related products.

3.1.3 Certifications

We hereby certify that the series of appliances specified below complies with the standard model described in the CE declaration of conformity.

CE number	CE-0085CP0089
NOx class	Class 5
Type of flue gas connection	<ul style="list-style-type: none"> • B₂₃ – B_{23P} • C₁₃ • C₃₃ • C₄₃ • C₅₃ • C₆₃ • C₈₃

3.2 Technical data

Tab.1 General

	Boiler speed	Unit	POWER HT+ 1.50	POWER HT+ 1.70	POWER HT+ 1.90	POWER HT + 1.110
Useful heat output at 80/60°C Heating mode	Minimum	kW	5.0	7.2	9.4	11.4
Useful heat output at 80/60°C Heating mode	Maximum	kW	45	65	85	102
Useful heat output at 50/30 °C Heating mode	Minimum	kW	5.4	7.8	10.2	12.3
Useful heat output at 50/30 °C Heating mode	Maximum	kW	48.6	70.2	91.8	110.2

	Boiler speed	Unit	POWER HT+ 1.50	POWER HT+ 1.70	POWER HT+ 1.90	POWER HT + 1.110
Heat input - Heating mode	Minimum	kW	5.1	7.4	9.7 ⁽¹⁾	11.7
Heat input - Heating mode	Maximum	kW	46.3	66.9	87.4	104.9
Heat input - Heating mode	Minimum	kW	5.6	8.2	10.7	12.9
Heat input - Heating mode	Maximum	kW	51.4	74.2	97.0	116.4
Efficiency at 80/60 °C - Heating mode under full load	Maximum	%	97.4	97.2	97.3	97.2
Efficiency at 50/30 °C -	Heating mode under full load	%	105.0	105.0	105.5	105.1
Efficiency - - Return temperature 30°C	Heating mode under part load	%	108.4	108.1	108.2	108.1

(1) The heat input with G31 gas is different and is 12.5 kW

Tab.2 Characteristics of the heating circuit

	Unit	POWER HT+ 1.50	POWER HT+ 1.70	POWER HT+ 1.90	POWER HT+ 1.110
Water content (excluding expansion vessel)	litre	2.81	4.98	8.34	9.83
Minimum operating pressure	MPa (bar)	0.05 (0.5)	0.05 (0.5)	0.05 (0.5)	0.05 (0.5)
Maximum operating pressure (MOP)	MPa (bar)	0.38 (3.8)	0.38 (3.8)	0.38 (3.8)	0.38 (3.8)
Maximum water temperature	°C	85	85	85	85
Maximum operating temperature	°C	80	80	80	80

Tab.3 Data on the gases and combustion gases

For gas flow rates at 15°C and 1013.25 hPA	Boiler speed	Unit	POWER HT + 1.50	POWER HT + 1.70	POWER HT + 1.90	POWER HT + 1.110
Consumption of natural gas (G20)	Minimum	m³/h	0.54	0.78	1.03	1.24
Consumption of natural gas (G20)	Maximum	m³/h	4.90	7.07	9.25	11.10
Consumption of natural gas (G25)	Minimum	m³/h	0.63	0.91	1.19	1.44
Consumption of natural gas (G25)	Maximum	m³/h	5.69	8.22	10.75	12.91
Consumption of Propane (G31)	Minimum	kg/h	0.40	0.57	0.97	0.91
Consumption of Propane (G31)	Maximum	kg/h	3.59	5.19	6.79	8.15
NOx emission according to EN297A3	Class 5	mg/kWh	29.8	34.8	39.5	24.7
Flue gas mass flow rate (G20)	Minimum	kg/h	7.2	14.4	18	18
Flue gas mass flow rate (G20)	Maximum	kg/h	75.6	111.6	144	169.2
Maximum flue gas temperature	Minimum	°C	92	76	70	70

Tab.4 Electrical characteristics

	Unit	POWER HT+ 1.50	POWER HT+ 1.70	POWER HT+ 1.90	POWER HT+ 1.110
Power supply voltage	VAC	230V 50Hz	230V 50Hz	230V 50Hz	230V 50Hz
Maximum absorbed power - Full load	W	100	117	146	185
Maximum absorbed power - Part load	W	24	24	24	24
Maximum absorbed power - Stand-by	W	2.7	3	3	3

Tab.5 Other characteristics

	Unit	POWER HT+ 1.50	POWER HT+ 1.70	POWER HT+ 1.90	POWER HT+ 1.110
Ingress protection rating		IP21	IP21	IP21	IP21
Weight empty	kg	60	70	104	109

3.2.1 Other technical parameters

Tab.6 Technical parameters for boiler space heaters

Product name			POWER HT + 1.50	POWER HT + 1.70	POWER HT + 1.90	POWER HT + 1.110
Condensing boiler			Yes	Yes	Yes	Yes
Low-temperature boiler ⁽¹⁾			No	No	No	No
B1 boiler			No	No	No	No
Cogeneration space heater			No	No	No	No
Combination heater			No	No	No	No
Rated heat output	<i>P_{rated}</i>	kW	45	65	85	102
Useful heat output at rated heat output and high temperature regime ⁽²⁾	<i>P₄</i>	kW	45.0	65.0	85.0	102.0
Useful heat output at 30% of rated heat output and low temperature regime ⁽¹⁾	<i>P₁</i>	kW	15.0	21.7	28.3	34.0
Seasonal space heating energy efficiency	<i>η_s</i>	%	93	93	-	-
Useful efficiency at rated heat output and high temperature regime ⁽²⁾	<i>η₄</i>	%	87.7	87.6	87.7	87.6
Useful efficiency at 30% of rated heat output and low temperature regime ⁽¹⁾	<i>η₁</i>	%	97.7	97.4	97.5	97.4
Auxiliary electricity consumption						
Full load	<i>el_{max}</i>	kW	0.100	0.117	0.146	0.185
Part load	<i>el_{min}</i>	kW	0.023	0.024	0.024	0.024
Stand-by	<i>P_{SB}</i>	kW	0.003	0.003	0.003	0.003
Other characteristics						
Standby heat loss	<i>P_{stby}</i>	kW	0.055	0.059	0.066	0.070
Ignition burner power consumption	<i>P_{ign}</i>	kW	-	-	-	-
Annual energy consumption	<i>Q_{HE}</i>	GJ	139	201	-	-
Sound power level, indoors	<i>L_{WA}</i>	dB	61	64	-	-
Emissions of nitrogen oxides	NO _x	mg/kWh	27	31	36	22
(1) Low temperature means for condensing boilers 30°C, for low temperature boilers 37°C and for other heaters 50°C return temperature (at heater inlet).						
(2) High temperature regime means 60°C return temperature at heater inlet and 80°C feed temperature at heater outlet.						



See
The back cover for contact details.

3.2.2 Sensor specifications

Tab.7 Heating flow sensor and return sensor

Temperature (in °C)	30	65	85
---------------------	----	----	----

Fig.3 Dimensions and connections: POWER HT+ 1.90 and POWER HT+ 1.110

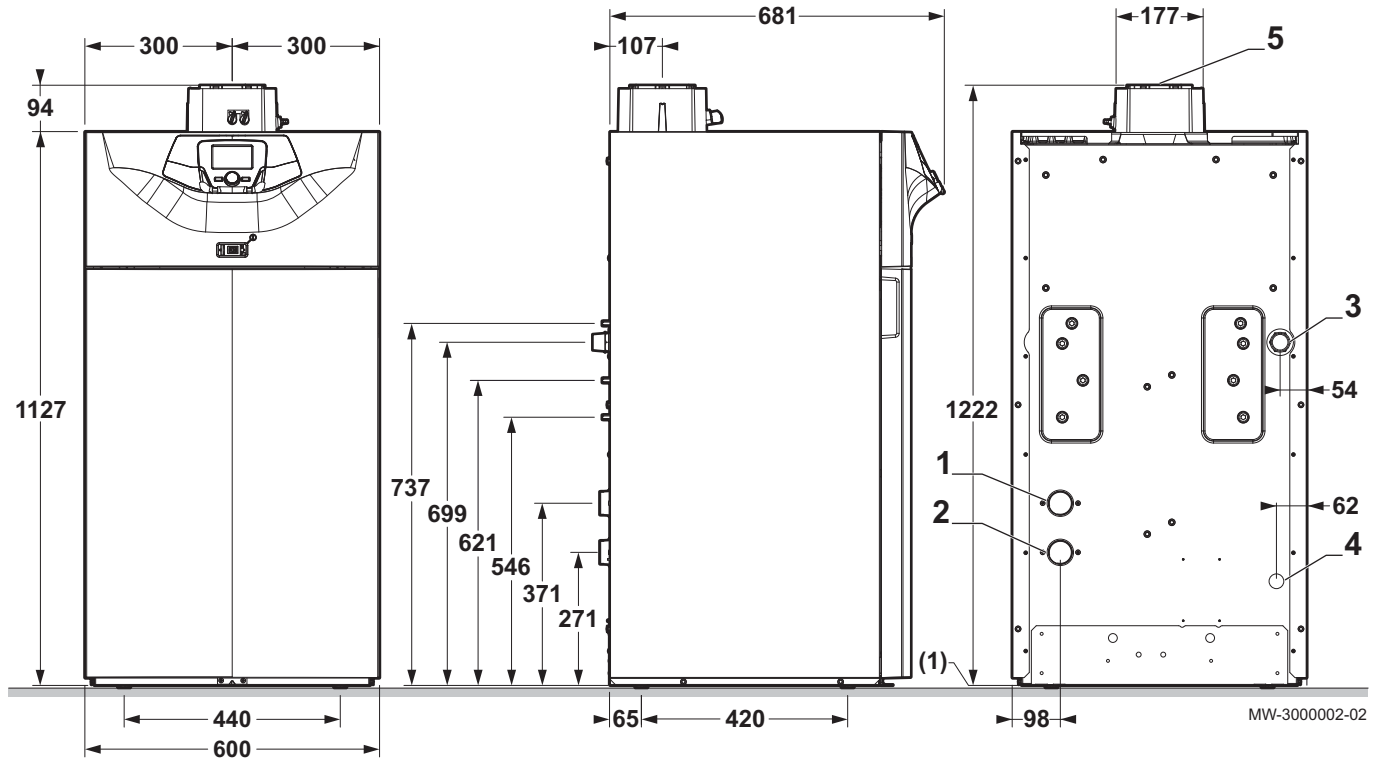

MW-3000002-02

- | | |
|------------------------------------|-------------------------------|
| 1 Heating circuit return (G1-1/2") | 4 Condensate discharge (DN18) |
| 2 Heating circuit flow (G1-1/2") | 5 Flue gas outlet (110/160) |
| 3 Gas inlet (G1") | (1) Adjustable feet |

3.4 Electrical diagram

Fig.4 Electrical diagram: POWER HT+ 1.50 - POWER HT+ 1.70

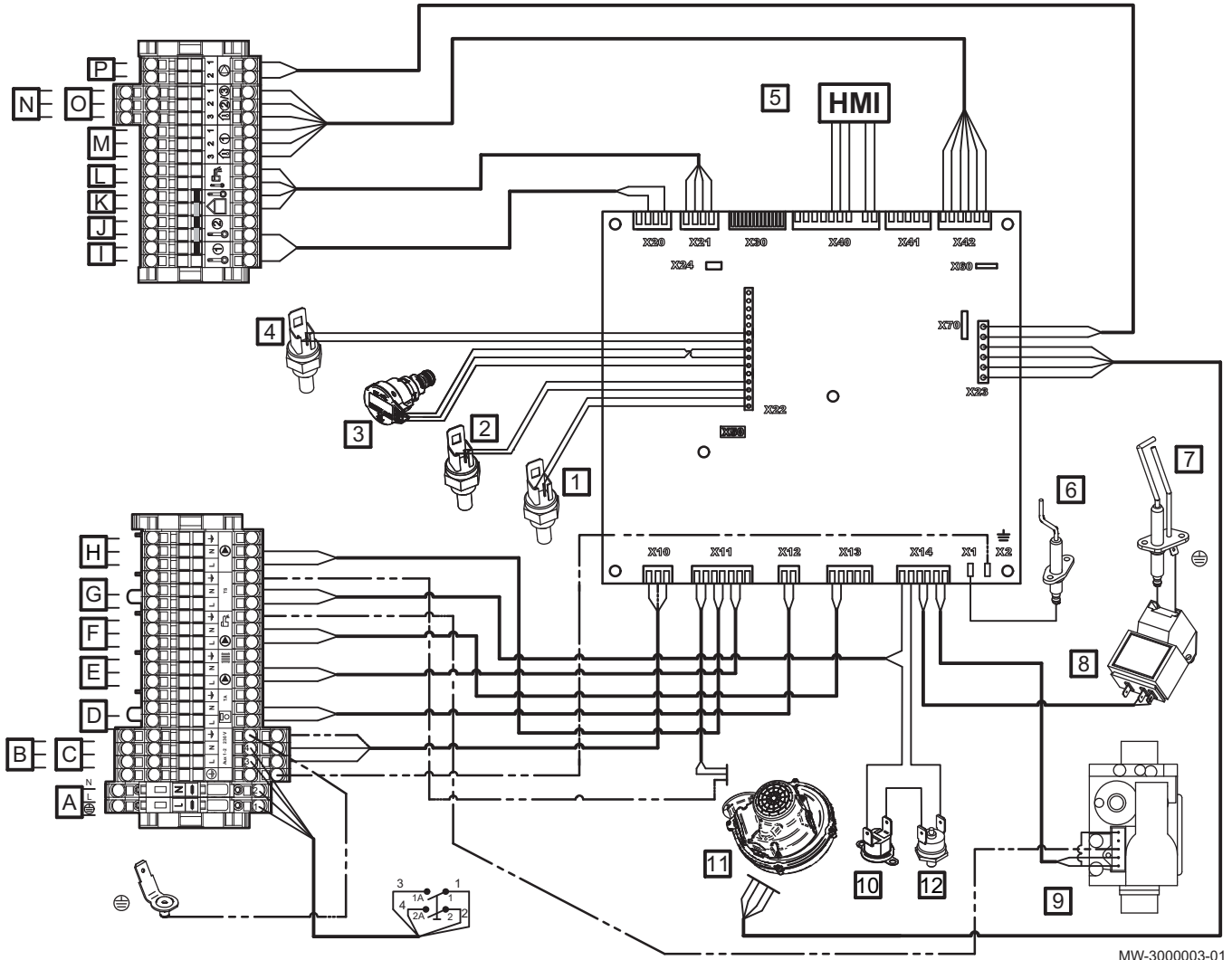

MW-300003-01

- ⊕ Earth POP rivet
- A Power supply 230 V 50 Hz
- B Power supply auxiliary circuit 1
- C Power supply auxiliary circuit 2
- D Room thermostat
- E Heating circuit pump
- F Domestic hot water pump
- G Safety contact
- H Boiler pump
- I Auxiliary sensor 1
- J Auxiliary sensor 2
- K Outside sensor
- L Domestic hot water sensor
- M Room temperature sensor 1
- N Room temperature sensor 2
- O Room temperature sensor 3
- P Boiler pump modulation (PWM)
- 1 Flow temperature sensor
- 2 Return temperature sensor
- 3 Hydraulic pressure sensor
- 4 Flue gas sensor
- 5 Control panel display
- 6 Ionisation probe
- 7 Spark plug
- 8 Igniter
- 9 Gas valve
- 10 Safety thermostat
- 11 Fan
- 12 Safety thermostat on the combustion chamber door

Fig.5 Electrical diagram: POWER HT+ 1.90 - POWER HT+ 1.110

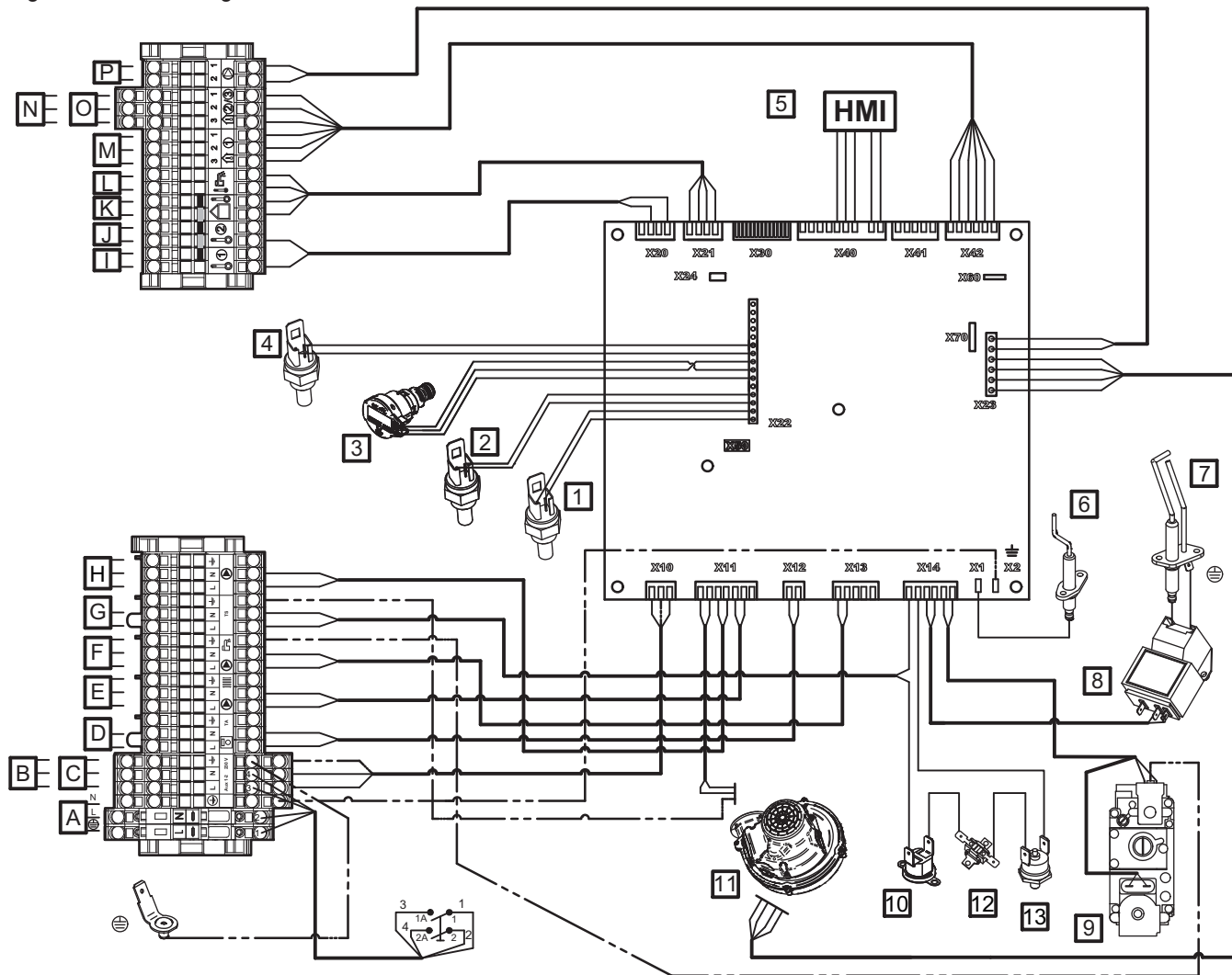

MW-3000004-03

- ⊕ Earth POP rivet
- A Power supply 230V 50Hz
- B Power supply auxiliary circuit 1
- C Power supply auxiliary circuit 2
- D Room thermostat
- E Heating circuit pump
- F Domestic hot water pump
- G Safety contact
- H Boiler pump
- I Auxiliary sensor 1
- J Auxiliary sensor 2
- K Outside sensor
- L Domestic hot water sensor
- M Room temperature sensor 1
- N Room temperature sensor 2
- O Room temperature sensor 3
- P Boiler pump modulation (PWM)
- 1 Flow temperature sensor
- 2 Return temperature sensor
- 3 Hydraulic pressure sensor
- 4 Flue gas sensor
- 5 Control panel display
- 6 Ionisation probe
- 7 Spark plug
- 8 Igniter
- 9 Gas valve
- 10 Safety thermostat
- 11 Fan
- 12 Thermal fuse
- 13 Safety thermostat on the combustion chamber door

4 Description of the product

4.1 General description

POWER HT + floor-standing condensing gas boilers have the following characteristics:

- Low pollutant emissions
- High efficiency heating
- Electronic control panel
- Perfectly suitable for cascade systems with several boilers.

4.2 Operating principle

4.2.1 Circulation pump



Note

The benchmark for the most efficient circulators is $EEL \leq 0.20$.

4.2.2 Gas/air setting

The casing fitted to the boiler is also used as an air box. Air is drawn in by the fan and gas injected into the Venturi by the fan intake. The fan speed is modulated according to the settings, the heat demand and the actual temperatures measured by the temperature sensors. The gas and air are mixed in the Venturi. The gas/air ratio command function accurately adjusts the quantities of gas and air required. This provides optimum combustion over the entire output range. The gas/air mixture is sent to the burner, located upstream of the heat exchanger.

4.2.3 Low-loss header (accessory)

The low-loss header is used to prevent interaction between the dynamic pressures within the boiler and the heating circuits. The low-loss header considerably reduces the variations in pressure and flow rate caused by the use of several circulating pumps in an installation and is used to manage flows in the installation and to control temperatures.

Fig.6 Boiler equipped with the low-loss header kit

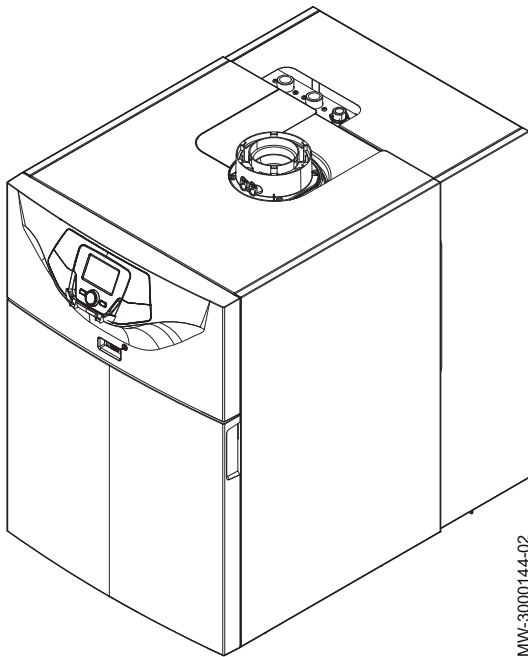
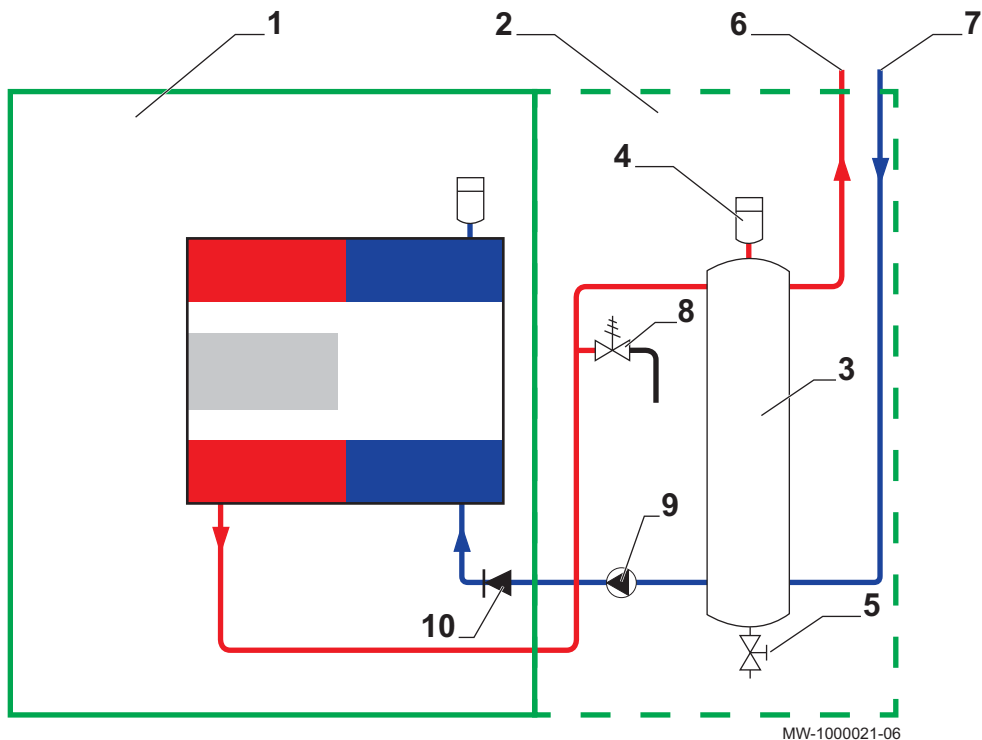

Fig.7 Functional diagram of a boiler with a low-loss header



- | | |
|-------------------------------|-------------------------------|
| 1 Boiler | 6 Heating circuit flow |
| 2 Low-loss header kit | 7 Heating circuit return |
| 3 Low-loss header (accessory) | 8 Safety valve |
| 4 Air vent | 9 Modulating circulating pump |
| 5 Drain valve | 10 Non-return valve |

4.2.4 System in cascade

Fig.8 Boilers in cascade

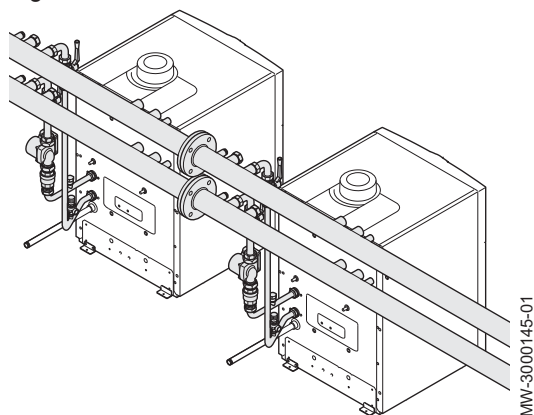

The boiler is ideally suited for a cascade system configuration. Use a boiler/cascade connection kit to connect boilers in cascade.

Note Please contact the After Sales Service for further information.

4.2.5 Settings and safety devices

Note

The settings and safety devices are only operational if the boiler is powered up.

Tab.10 Description of the safety devices

Device	Description
Safety thermostats	<p>The safety thermostats suspend the supply of gas to the burner if the water in the primary circuit overheats. To resume normal operation of the boiler, eliminate the cause of this interruption.</p> <p> Caution The safety thermostats must in no circumstances be switched off or disconnected.</p>
NTC flue gas sensor	The control panel blocks the gas supply to the burner in the event of overheating. To resume normal operation of the boiler, switch off the boiler and switch it back on again with the ON/OFF switch.
Flame detector by ionisation	The boiler is put into safety shut-down in the event of gas shortage or incomplete inter-ignition on the burner.
Hydraulic pressure switch	<p>Thanks to this device, the burner can only operate if the system pressure is higher than 0.5 bar (0.05 MPa).</p> <p>When the pressure switch detects a pressure lower than 0.8 bar (0.08 MPa), a warning message is displayed, without stopping the circulating pump.</p>
Post-circulating pump	After the burner stops, depending on the room thermostat setting and if in heating mode, the circulating pump runs for a further 3 minutes.
Frost protection device	<p>When the flow temperature is lower than 5°C, the burner starts up and runs until the flow temperature reaches 15°C. This device runs under the following conditions:</p> <ul style="list-style-type: none"> • The boiler is switched on • The gas supply is working • The pressure in the system is higher than 0.5 bar (0,05 MPa)
Anti-blocking of the pump	<p>If there are no heating or domestic hot water requirements for 24 consecutive hours, the pumps start up automatically and run for 10 seconds.</p> <p>The pumps connected directly to the appliance's terminal blocks are started up every Friday at 10:00 a.m. and run for 30 seconds.</p>
Anticipatory start-up of the circulating pumps	In heating mode only, the appliance can start up the circulating pumps before burner ignition. The duration and activation of anticipatory start-up depends on the conditions of installation and the operating temperatures. The duration of anticipatory start-up of the circulating pumps therefore varies from a few seconds to several minutes.

4.3 Main components

Fig.9 POWER HT+ 1.50 and POWER HT+ 1.70

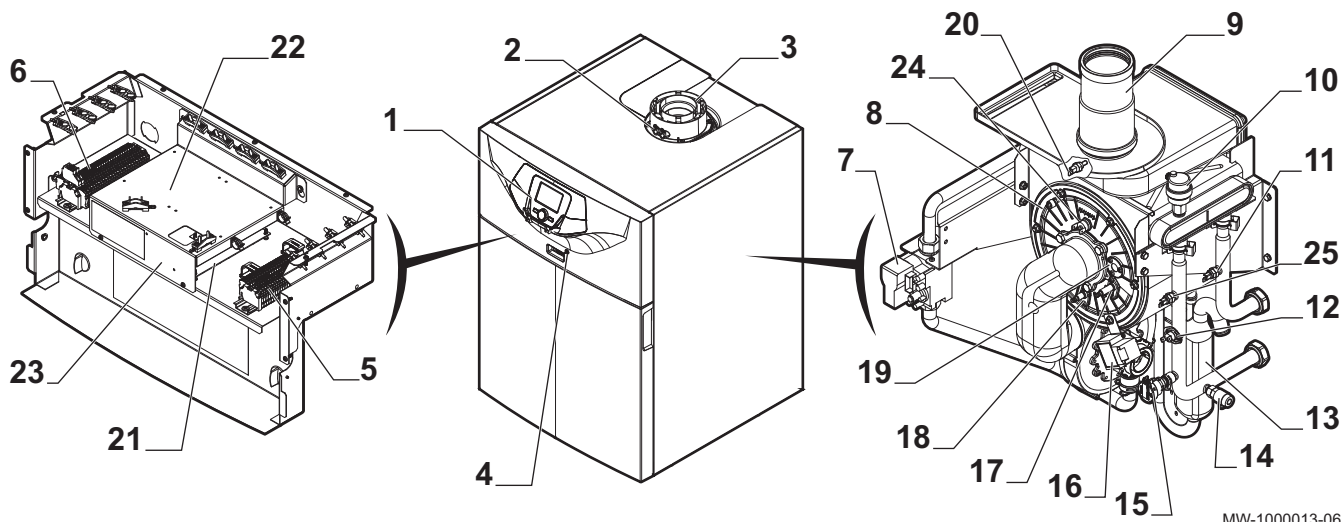

- | | |
|--|---|
| <ul style="list-style-type: none"> 1 Control panel 2 Flue gas measuring point 3 Flue gas connection 4 On/Off button 5 Terminal block for the sensors and the remote control 6 Power supply terminal block 7 Gas valve 8 Burner 9 Flue gas fitting 10 Automatic air vent 11 Return temperature sensor 12 Safety thermostat 13 Condensate siphon 14 Drain valve 15 Hydraulic pressure sensor 16 Ignition transformer | <ul style="list-style-type: none"> 17 Ignition electrode 18 Ionisation probe 19 Flame inspection window 20 Flue gas sensor 21 Controller PCB 22 Mounting point for a maximum of two AVS 75 modules. A third AVS 75 module can be used by the boiler but must be fixed to the wall and powered externally. 23 Mounting point for communication module OCI 345 <p>⚠ Caution
 Danger of short circuit on the OCI 345 communication module if it is fixed in another emplacement.</p> <ul style="list-style-type: none"> 24 Safety thermostat on the combustion chamber door 25 Flow temperature sensor |
|--|---|

Fig.10 POWER HT+ 1.90 and POWER HT+ 1.110

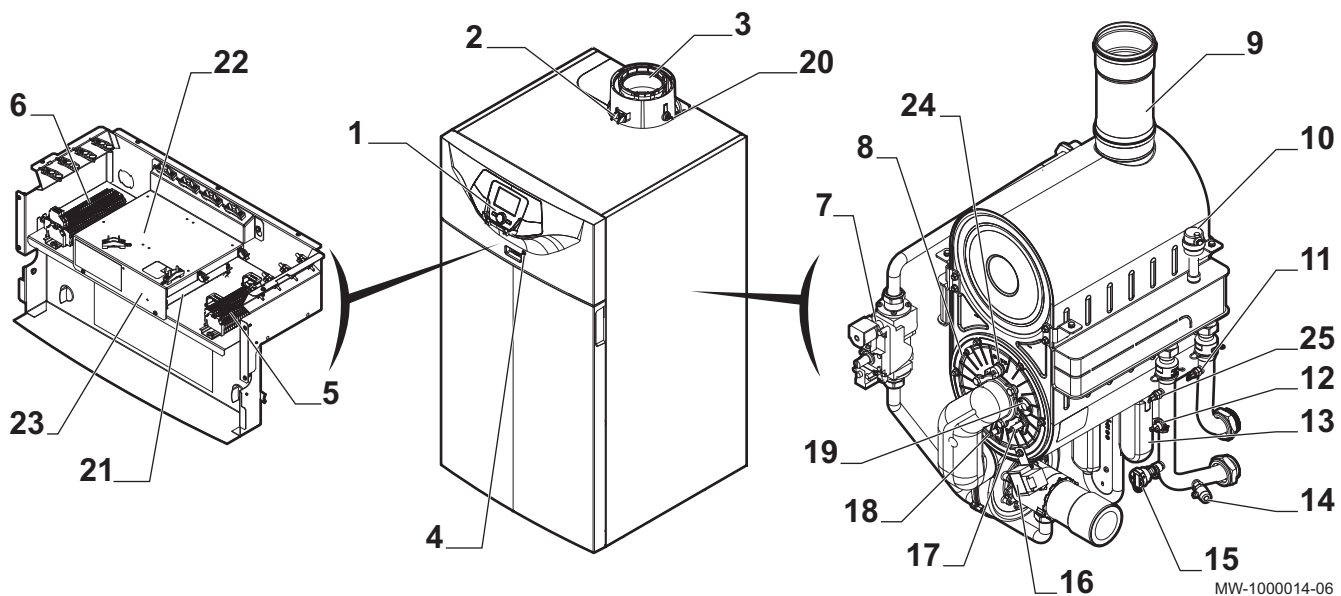

- | | |
|---|---|
| <ul style="list-style-type: none"> 1 Control panel 2 Flue gas measuring point 3 Flue gas connection 4 On/Off button | <ul style="list-style-type: none"> 5 Terminal block for the sensors and the remote control 6 Power supply terminal block 7 Gas valve |
|---|---|

4 Description of the product

- 8 Burner
- 9 Flue gas fitting
- 10 Automatic air vent
- 11 Return temperature sensor
- 12 Safety thermostat
- 13 Condensate siphon
- 14 Drain valve
- 15 Hydraulic pressure sensor
- 16 Ignition transformer
- 17 Ignition electrode
- 18 Ionisation probe
- 19 Flame inspection window
- 20 Flue gas sensor

- 21 Controller PCB
 - 22 Mounting point for a maximum of two AVS 75 modules. A third AVS 75 module can be used by the boiler but must be fixed to the wall and powered externally.
 - 23 Mounting point for communication module OCI 345
- Caution**
 Danger of short circuit on the OCI 345 module if it is fixed in another emplacement.
- 24 Safety thermostat on the combustion chamber door
 - 25 Flow temperature sensor

Fig.11 Burner description



- 1 Burner
- 2 Burner bracket
- 3 Safety thermostat on the combustion chamber door
- 4 Flame inspection window
- 5 Spark plug
- 6 Ionisation probe
- 7 Gas collector
- 8 Venturi
- 9 Fan
- 10 Silencer (POWER HT+ 1.90 model only)
- 11 Igniter

4.4 Control panel description

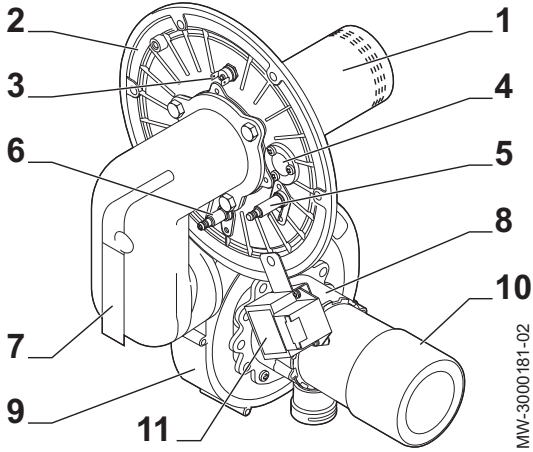
Fig.12 Control panel keys

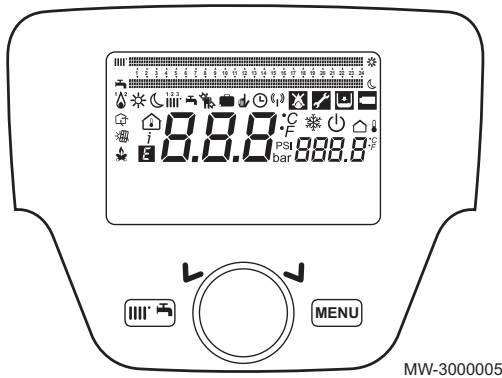

4.4.1 Description of the keys















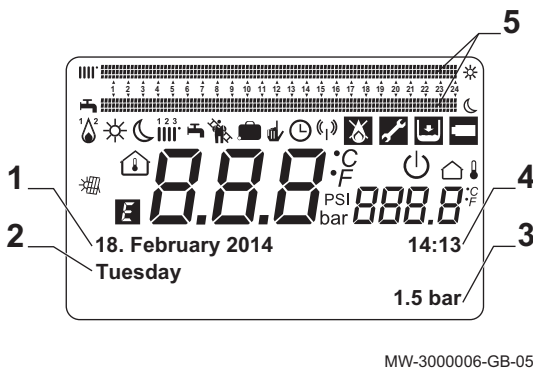

















-  Operating mode key
 This key is used to access the shortcuts menu
 -  Menu key
 -  Rotary selection and confirmation button
-  **For more information, see**
 List of parameters, page 61
 Shortcuts menu, page 61

Fig.13 Symbols on the control panel



4.4.2 Description of the symbols

-  Burner lit
 -  (1): Output < 70%
 -  (2): Output > 70%
 -  Operating mode: Comfort room temperature
 -  Operating mode: Reduced room temperature
 -  Operating mode: Heating
 -  (1): Zone 1 active
 -  (2): Zone 2 active
 -  (3): Zone 3 active
 -  Operating mode: Domestic hot water activated
- Note**
 The domestic hot water  can be activated. The heating  is then deactivated.
-  Sweep Function activated

	Holidays program function activated
	Operating mode: Manual
	Operating mode: Automatic
	Data transmission: only when the wireless device is connected.
	Error: the burner cannot start up
	Error: After Sales Service intervention required
	Hydraulic pressure too low
	Room temperature (°C)
	Temperature and hydraulic pressure units: international system or imperial system.
	Protection Mode active: the boiler's frost protection is activated.
	Outside temperature (°C)
	Solar integration available
	Generic error
1	Date: day, month, year
2	Day of the week
3	Boiler / heating circuit pressure
4	Clock: hours and minutes
5	Comfort period indicators over 24 hours in Domestic Hot Water mode and Heating mode

4.5 Standard delivery

The POWER HT + boiler comes in a package that includes:

- A floor-standing gas boiler
- An installation and service manual
- A user guide
- A data plate

4.6 Accessories and options

Tab.11 Package references

Description	Package
Outside sensor QAC34	C7104873
G25.1/G27 conversion kit for POWER HT+ 1.50	711137202
G25.1/G27 conversion kit for POWER HT+ 1.70	711152602
G27 conversion kit for POWER HT+ 1.90	711152702
G27 conversion kit for POWER HT+ 1.110	711153302
G25 conversion kit for POWER HT+ 1.90	710984801
G25 conversion kit for POWER HT+ 1.110	710984902
G31 conversion kit for POWER HT+ 1.50	710718605
G31 conversion kit for POWER HT+ 1.70	710718803
G31 conversion kit for POWER HT+ 1.90	710718903
G31 conversion kit for POWER HT+ 1.110	710719003
Low-loss header kit - POWER HT+ 1.50 – POWER HT+ 1.70	7607401
Low-loss header kit - POWER HT+ 1.90 – POWER HT+ 1.110	7606357
Cascade communication module OCI 345	710440803
Module AVS75	C17201811
AVS75 module with wall-hanging kit	710503705

5 Before installation

5.1 Installation regulations



Warning

The boiler must be installed by a qualified installer in accordance with local and national regulations.

5.2 Installation requirements

5.2.1 Water treatment

In many cases, the boiler and the heating system can be filled with mains water, without treating the water.



Caution

Do not add any chemical products to the central heating water without first consulting a water treatment specialist. For example: antifreeze, water softeners, products to increase or reduce the pH value, chemical additives and/or inhibitors. These may cause faults in the boiler and damage the heat exchanger.



Note

- Flush the installation with at least 3 times the volume of water contained in the central heating system.
- Flush the DHW circuit with at least 20 times its volume of water.

The water in the installation must comply with following characteristics:

Tab.12 Heating water specifications

Specification	Unit	Total output of the installation (kW)			
		≤ 70	70 - 200	200 - 550	> 550
Degree of acidity (untreated water)	pH	7.5 - 9.5	7.5 - 9.5	7.5 - 9.5	7.5 - 9.5
Degree of acidity (treated water)	pH	7.5 - 9.5	7.5 - 9.5	7.5 - 9.5	7.5 - 9.5
Conductivity at 25°C	µS/cm	≤ 800	≤ 800	≤ 800	≤ 800
Chlorides	mg/litre	≤ 50	≤ 50	≤ 50	≤ 50
Other components	mg/litre	< 1	< 1	< 1	< 1
Total water hardness ⁽¹⁾	°f	1 - 35	1 - 20	1 - 15	1 - 5
	°dH	0.5 - 20.0	0.5 - 11.2	0.5 - 8.4	0.5 - 2.8
	mmol/litre	0.1 - 3.5	0.1 - 2.0	0.1 - 1.5	0.1 - 0.5

(1) For installations with constant heating and a maximum total system output of 200 kW, the appropriate maximum total water hardness is 8.4°dH (1.5 mmol/l, 15°f). For installations of more than 200 kW, the appropriate maximum total hardness is 2.8°dH (0.5 mmol/l, 5°f).



Note

If water treatment is necessary, Baxi recommends the following manufacturers:

- Cillit
- Climalife
- Fernox
- Permo
- Sentinel

5.2.2 Gas supply

- Before mounting, check that the gas meter has sufficient capacity (in m³/h). To do this, you should bear in mind the consumption of all appliances. If the capacity of the gas meter is too low, inform the gas supply company.
- The boilers are designed to run on natural gas G20 and can be converted to run on G25 or G31 gas.

5.2.3 Electrical power supply

Power supply voltage	230 V AC/50 Hz
----------------------	----------------



Caution

Please ensure the polarities shown on the terminals are followed, i.e live (L), neutral (N) and earth (\perp)

5.2.4 Circulating pump

The boiler's water flow rates must be higher than or equal to the specifications in the table below:

Tab.13 Water flow rates in the boiler

Working flow rate with the low-loss header kit	Unit	POWER HT+ 1.50	POWER HT+ 1.70	POWER HT+ 1.90	POWER HT+ 1.110
Minimum flow rate	litres/hour	800	1500	2000	2250
Maximum flow	litres/hour	2450	3500	4600	4800



Note

ΔT : Temperature difference between the flow water and the return water in the boiler

- 1 Q flow rate (litres/hour)
- 2 H pressure in metres of water column (mWC)
- 3 Operating water flow rate at nominal heat output = 1330 litres/hour where $\Delta T = 30^\circ\text{C}$
- 4 Operating water flow rate at nominal heat output = 2000 litres/hour where $\Delta T = 20^\circ\text{C}$
- 5 Operating water flow rate at nominal heat output = 2660 litres/hour where $\Delta T = 15^\circ\text{C}$

Fig.14 Pressure drops for POWER HT+ 1.50

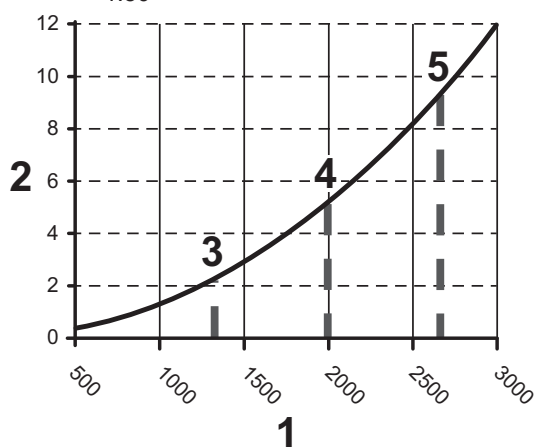

MW-3000007-01

Fig.15 Pressure drops for POWER HT+ 1.70

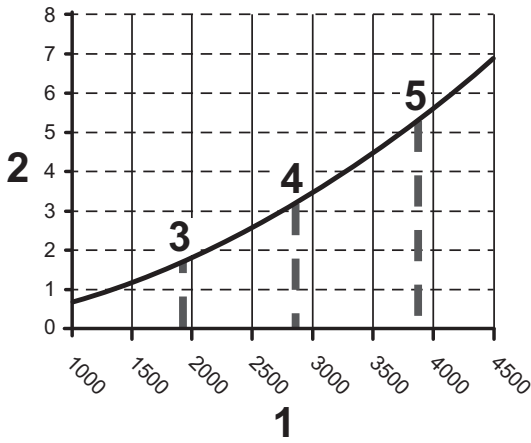

- 1 Q flow rate (litres/hour)
- 2 H pressure in metres of water column (mWC)
- 3 Operating water flow rate at nominal heat output = 1920 litres/hour where $\Delta T = 30^\circ C$
- 4 Operating water flow rate at nominal heat output = 2880 litres/hour where $\Delta T = 20^\circ C$
- 5 Operating water flow rate at nominal heat output = 3840 litres/hour where $\Delta T = 15^\circ C$

Fig.16 Pressure drops for POWER HT+ 1.90

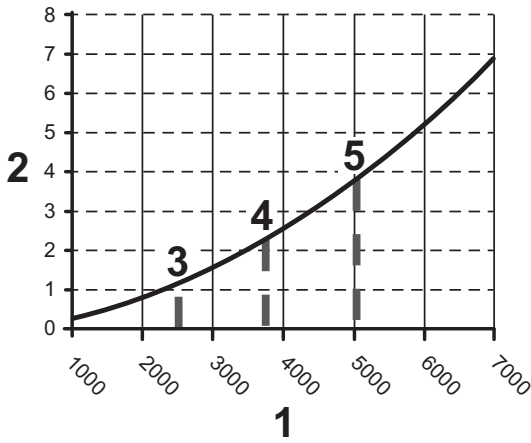

- 1 Q flow rate (litres/hour)
- 2 H pressure in metres of water column (mWC)
- 3 Operating water flow rate at nominal heat output = 2510 litres/hour where $\Delta T = 30^\circ C$
- 4 Operating water flow rate at nominal heat output = 3760 litres/hour where $\Delta T = 20^\circ C$
- 5 Operating water flow rate at nominal heat output = 5020 litres/hour where $\Delta T = 15^\circ C$

Fig.17 Pressure drops for POWER HT+ 1.110

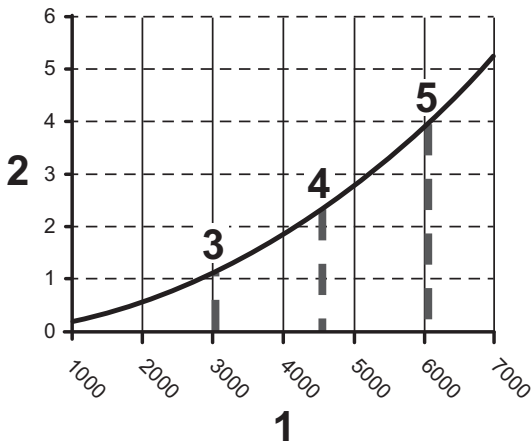

- 1 Q flow rate (litres/hour)
- 2 H pressure in metres of water column (mWC)
- 3 Operating water flow rate at nominal heat output = 3010 litres/hour where $\Delta T = 30^\circ C$
- 4 Operating water flow rate at nominal heat output = 4520 litres/hour where $\Delta T = 20^\circ C$
- 5 Operating water flow rate at nominal heat output = 6020 litres/hour where $\Delta T = 15^\circ C$

5.3 Choice of the location

Before mounting the boiler, decide on the ideal position for mounting, bearing in mind any Directives and the dimensions of the appliance.

- Install the boiler on a solid, stable structure capable of bearing the weight of the appliance when full of water and fully equipped.
- When choosing the position for mounting the boiler, bear in mind the authorised position of the combustion gas discharge outlets and the air intake vent.

**Caution**

It is forbidden to store inflammable products and materials in the boiler room or close to the boiler, even temporarily.

**Caution**

- The boiler must be installed in a frost-free environment.
- Make sure there is a connection to the water drainage system close to the boiler to discharge the condensates.

5.3.1 Ventilation

To allow the intake of combustion air, sufficient ventilation must be provided in the boiler room, for which the cross section and position must satisfy the regulations in force in the country in which the boiler is installed:

If the boiler is installed in closed premises, respect the minimum dimensions given in the diagram below. Also allow for openings to obviate the following hazards:

- Accumulation of gas
- Overheating of the premises

■ Ventilation to be provided for the boilers

Fig.18 Ventilation to be provided for the boilers

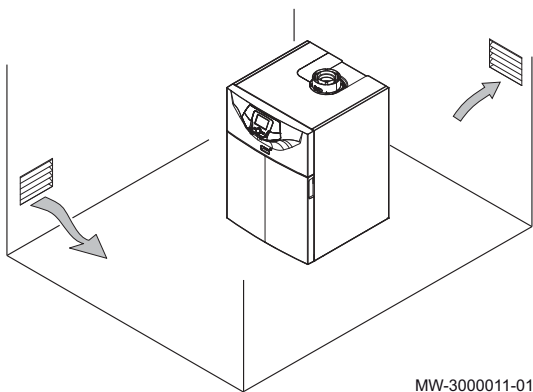

MW-3000011-01

Fig.19 Ventilation to be provided for boilers with low-loss header (optional)

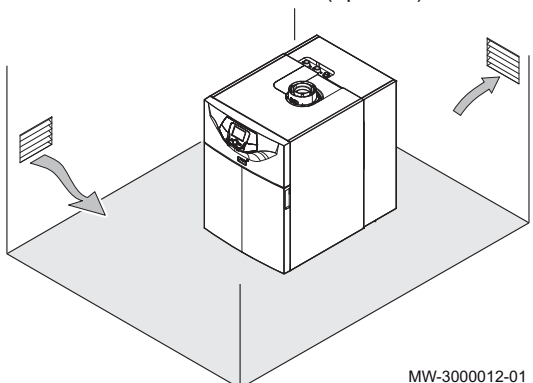

MW-3000012-01

■ Ventilation to be provided for boilers with low-loss header (optional)

5.3.2 Overall space needed for the boiler

To ensure adequate access to the appliance and facilitate maintenance, allow sufficient space around the boiler, according to the information provided.

Fig.20 Space to be allowed for the boilers

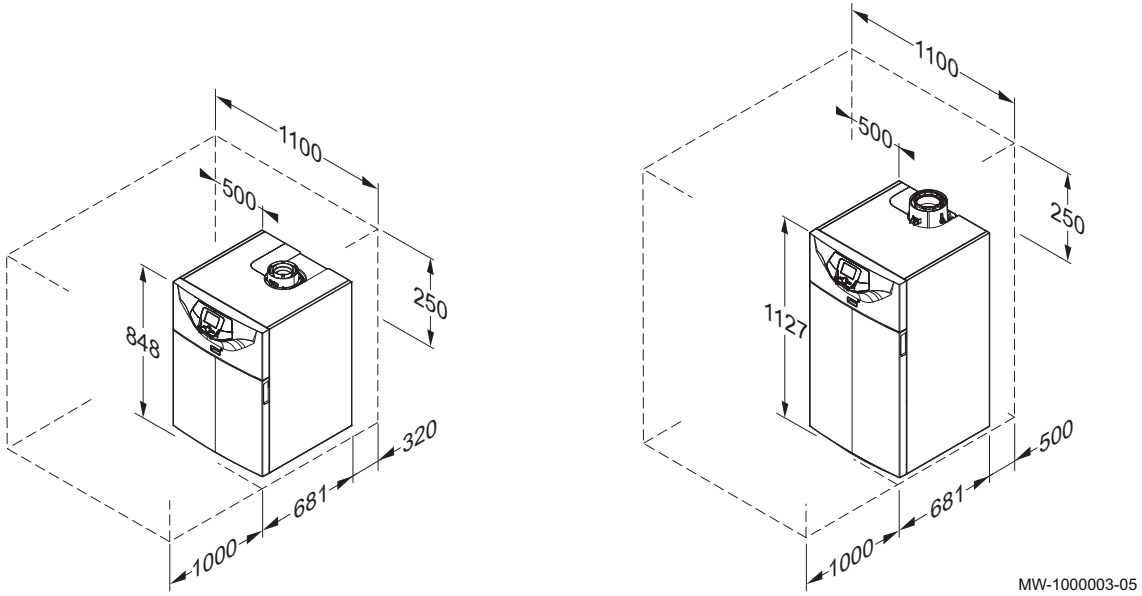

Fig.21 Space to be allowed for boilers equipped with a low-loss header kit

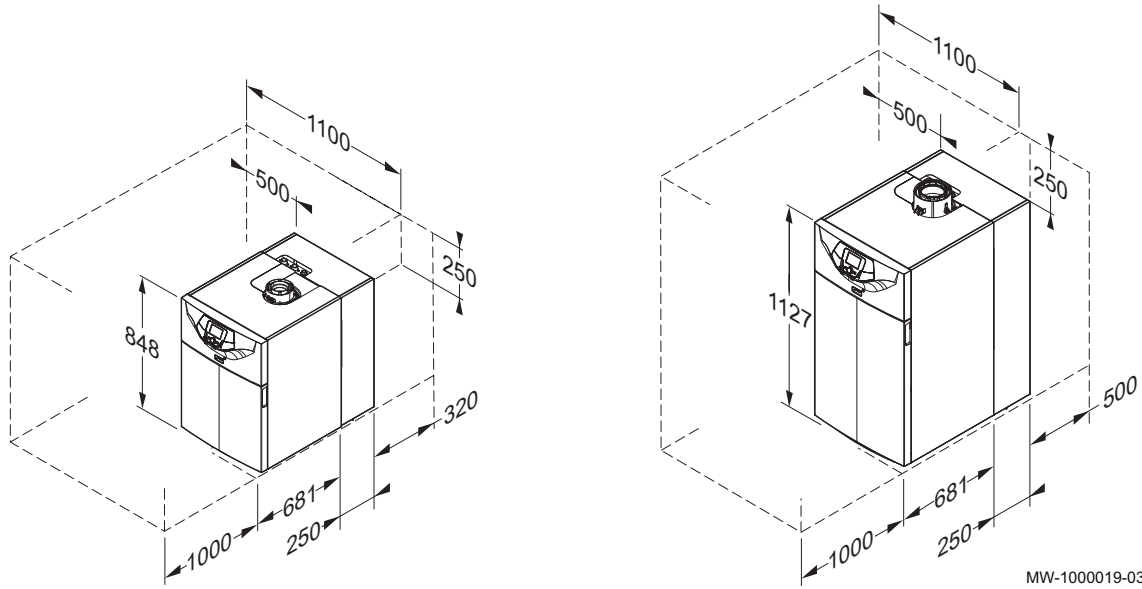
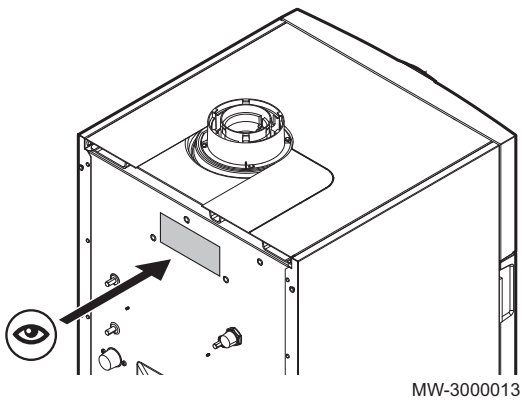

Fig.22 Location of the data plate



5.3.3 Data plate

The data plate is located on the back of the boiler. The data plate provides important information regarding the appliance:

- Serial number
- Model
- Gas category
- etc.

**Caution**

A second data plate is provided in the instructions bag. The second data plate should be affixed to a visible part of the boiler when installation has been completed. If the boiler is equipped with a low-loss header kit, a position on the side of the boiler is preferable.

5.3.4 Selecting the position for the outside temperature sensor (optional)

It is important to select a position that allows the sensor to measure the outside conditions correctly and effectively.

■ Recommended positions

Place the outside sensor in a position that covers the following characteristics:

- On a façade of the area to be heated, on the north if possible.
- Half way up the wall of the area to be heated.
- Under the influence of changes in the weather.
- Protected from direct sunlight.
- Easy to access.

Fig.23 Recommended positions for the outside sensor

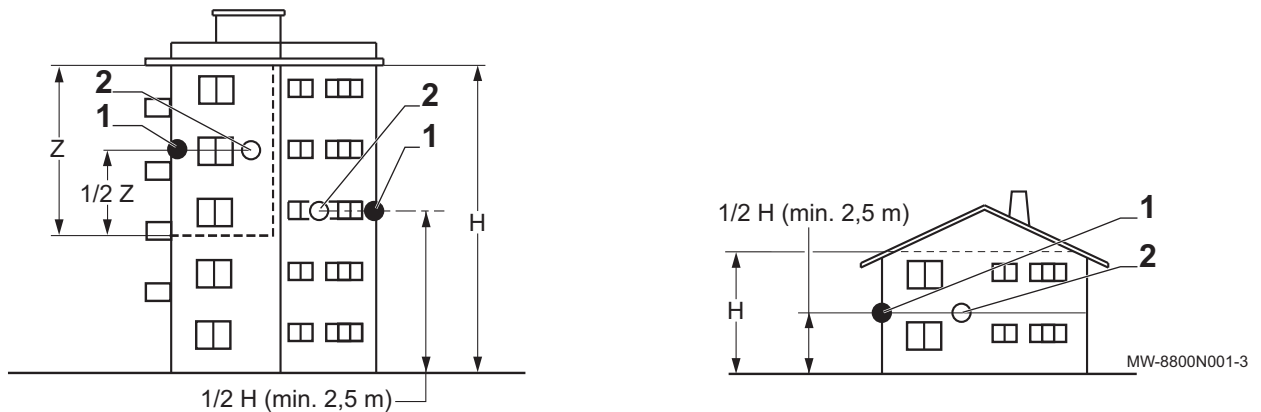

- 1 Recommended position
2 Possible position

- H Inhabited height controlled by the sensor
Z Inhabited area controlled by the sensor

■ Positions to be avoided

Avoid placing the outside sensor in a position with the following characteristics:

- Masked by part of the building (balcony, roof, etc.).
- Close to a disruptive heat source (sun, chimney, ventilation grid, etc.).

Fig.24 Positions to be avoided for the outside sensor

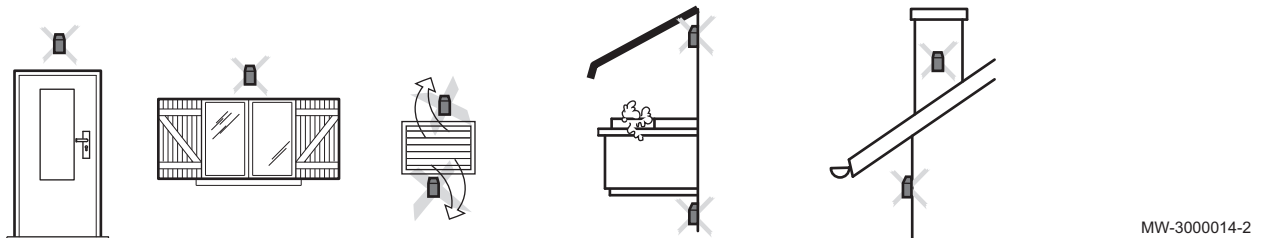

5.4 Transport

Fig.25 Transport precautions

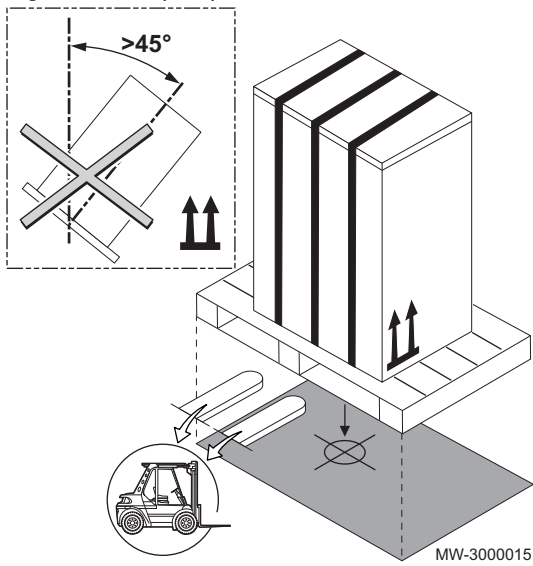

Caution

- Have at least two people standing by.
 - Handle the appliance with gloves.
- Transport the pallet carrying the appliance using a pallet truck, a forklift truck or a 4-wheel removals cart.
 - Do not use the top cover of the appliance for transport lifting.
 - Transport the appliance vertically.

5.5 Unpacking and initial preparation

Fig.26 Unpacking

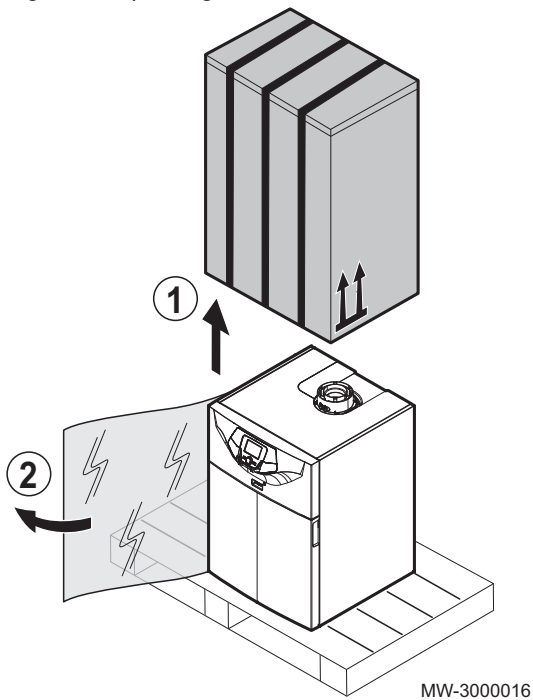

1. Remove the cardboard packaging.
2. Remove the plastic protection and the polystyrene cover.

Fig.27 Preparation

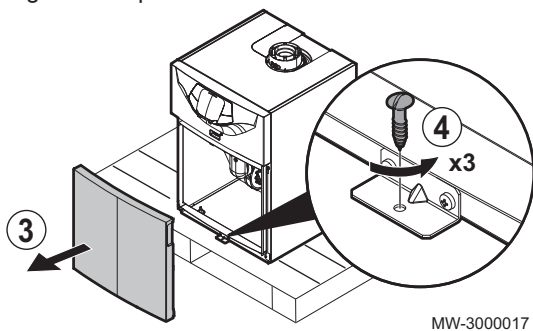

3. Remove the front panel by pulling firmly on the notches provided.
4. Remove the 4 screws holding the boiler in place on the pallet.
5. Take the condensates hose that you will find in the boiler and connect it to the condensates discharge.
6. Put the boiler in its intended position.



Caution

Moving the boiler is a job for two people.

Fig.28 Removing the struts

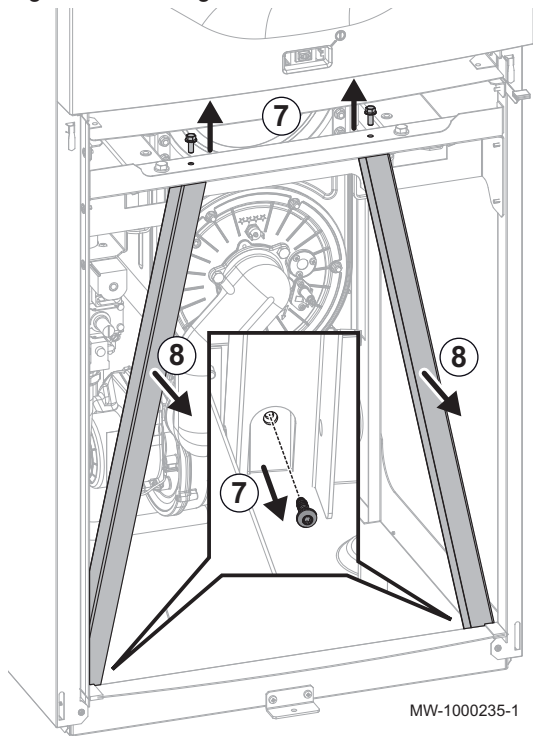

7. Remove the 4 screws holding the struts in place (for POWER HT+ 1.90 and POWER HT+ 1.110 only)
8. Remove the struts.
9. Level the boiler using the adjustable feet.

MW-1000235-1

5.6 Connecting diagrams

5.6.1 Connection diagram: 1 boiler + 1 direct circuit + 1 domestic hot water tank

Fig.29 1 boiler + 1 direct circuit + 1 domestic hot water tank

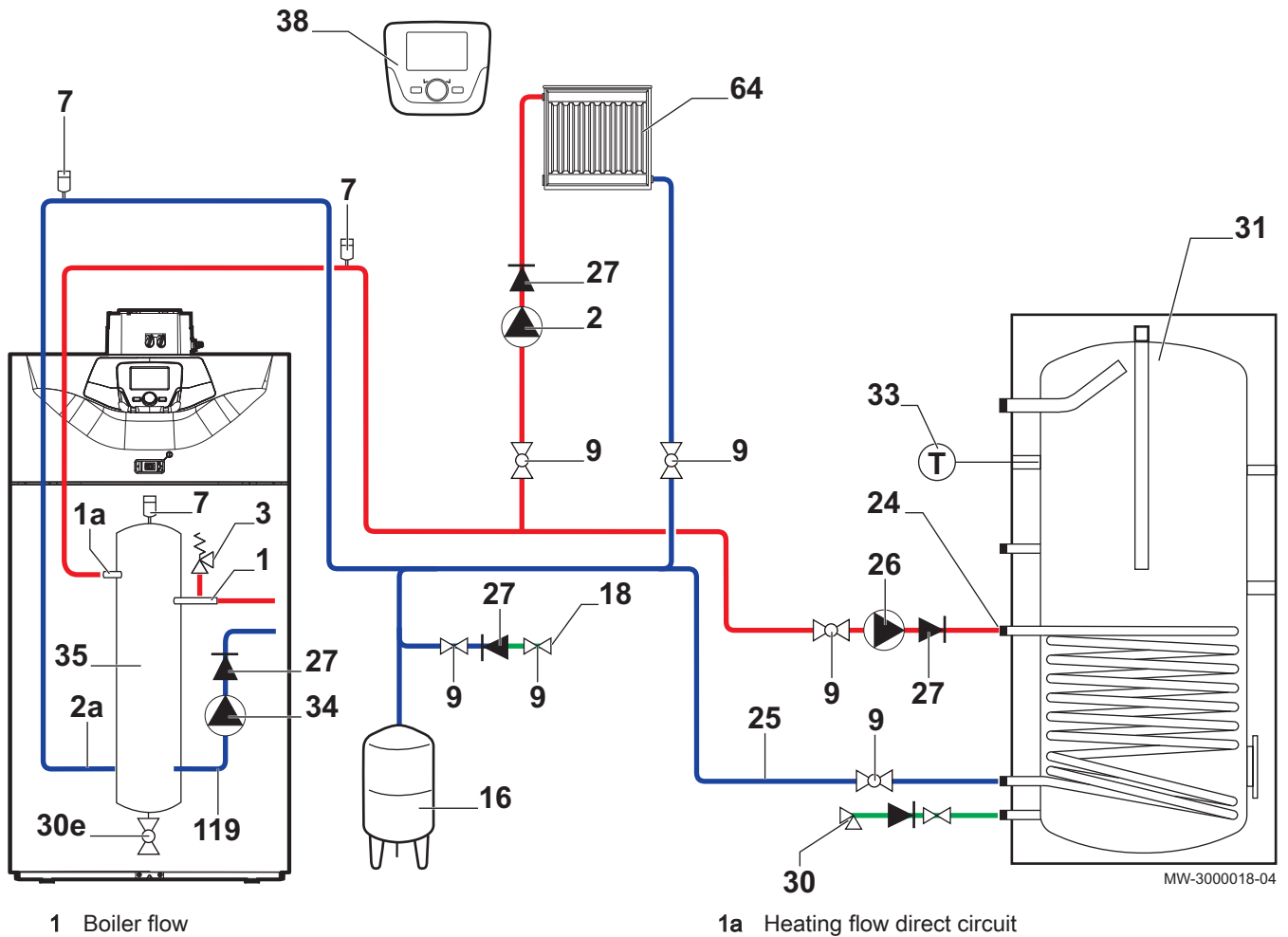

MW-3000018-04

- 2 Heating pump
- 2a Heating return direct circuit
- 3 4 bar (0.4 MPa) safety valve
- 7 Automatic air vent
- 9 Isolation valve
- 16 Closed expansion vessel
- 18 Heating circuit fill point
- 24 Domestic hot water tank exchanger primary inlet
- 25 Domestic hot water tank exchanger primary outlet
- 26 DHW load pump
- 27 Non-return valve
- 30 Calibrated and sealed safety unit
- 30e Drain valve
- 31 Independent domestic hot water tank
- 33 Domestic hot water temperature sensor
- 34 Modulating boiler pump
- 35 Low-loss header (accessory)
- 38 Remote control
- 64 Direct heating circuit
- 65 Heating circuit with mixing valve
- 117 Three-way mixing valve
- 119 Boiler return

5.6.2 Connection diagram: 1 boiler + 1 direct circuit + 1 underfloor heating circuit + 1 domestic hot water tank

Fig.30 1 boiler + 1 direct circuit + 1 underfloor heating circuit + 1 domestic hot water tank

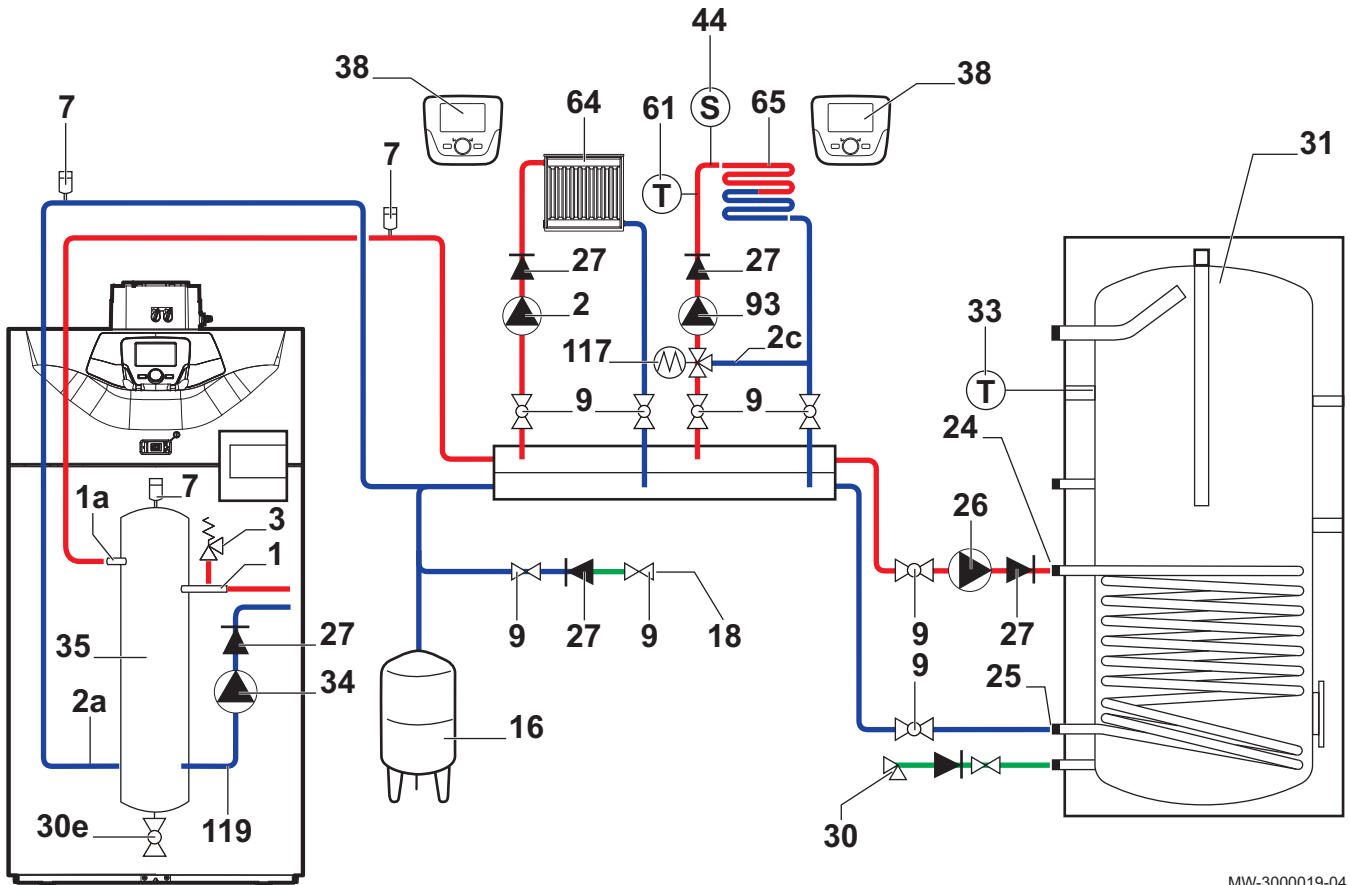

MW-3000019-04

- 1 Boiler flow
- 1a Heating flow
- 2 Heating pump
- 2a Heating return
- 2c Three-way valve bypass
- 3 4 bar (0.4 MPa) safety valve
- 7 Automatic air vent
- 9 Isolation valve
- 16 Closed expansion vessel
- 18 Heating circuit fill point
- 24 Domestic hot water tank exchanger primary inlet
- 25 Domestic hot water tank exchanger primary outlet
- 26 DHW load pump
- 27 Non-return valve
- 30 Calibrated and sealed safety unit
- 30e Drain valve
- 31 Independent domestic hot water tank
- 33 Domestic hot water temperature sensor
- 34 Modulating boiler pump
- 35 Low-loss header (optional)
- 38 Remote control with or without room temperature sensor
- 44
- 61 Thermometer
- 64 Direct heating circuit (example: radiators)
- 65 Heating circuit with mixing valve, may be low temperature heating circuit (underfloor heating or radiators)
- 93 Heating pump for underfloor heating circuit
- 117 Three-way mixing valve
- 119 Boiler return



For more information, see

Electrical connection: 1 boiler + 1 direct circuit + 1 underfloor heating circuit + 1 domestic hot water tank, page 49

5.6.3 Connection diagram: Boilers in cascade + 1 direct circuit + 1 underfloor heating circuit + 1 domestic hot water tank

Fig.31 Boilers in cascade + 1 direct circuit + 1 underfloor heating circuit + 1 domestic hot water tank

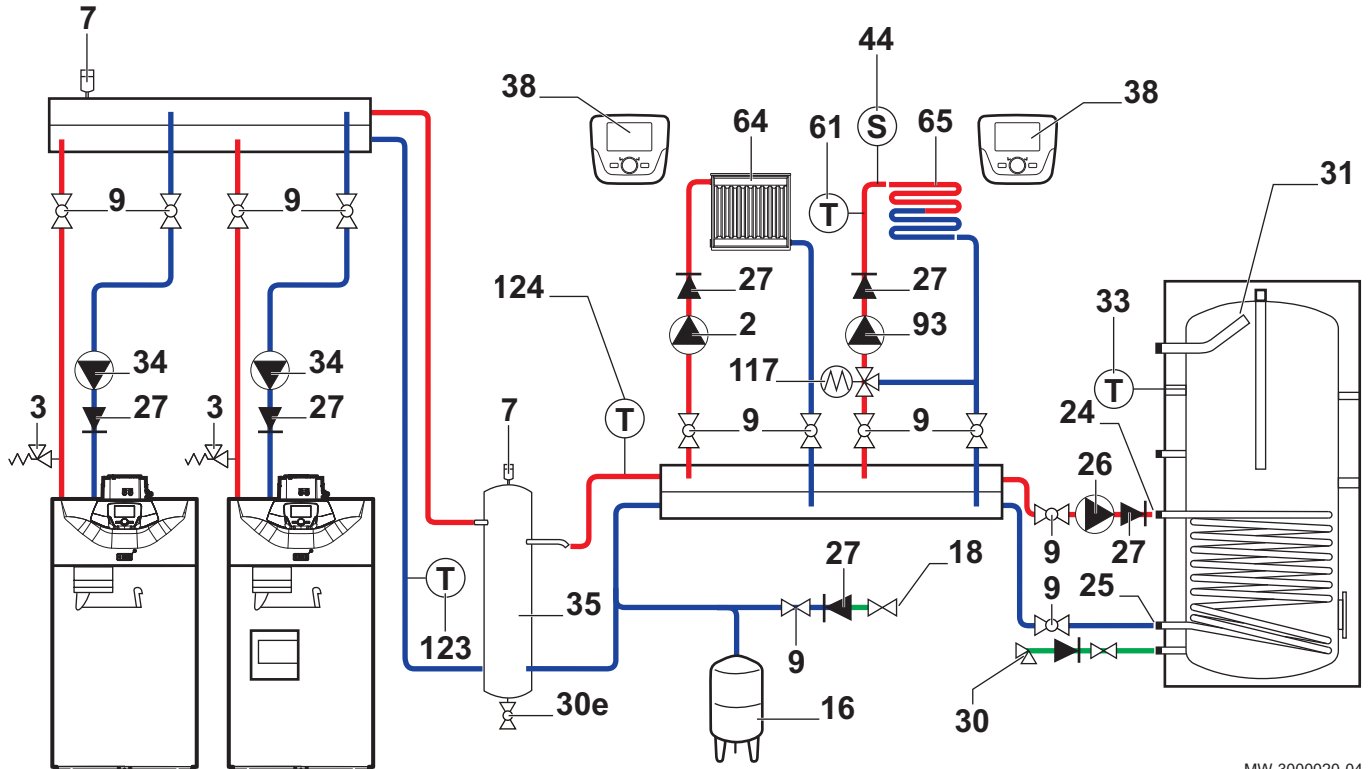

MW-3000020-04

- | | |
|---|--|
| 2 Heating pump direct circuit | 34 Modulating boiler pump |
| 3 4 bar (0.4 MPa) safety valve | 35 Low-loss header |
| 7 Automatic air vent | 38 Remote control with or without room temperature sensor |
| 9 Isolation valve | 44 |
| 16 Closed expansion vessel | 61 Thermometer |
| 18 Heating circuit fill point | 64 Direct heating circuit (example: radiators) |
| 24 Domestic hot water tank exchanger primary inlet | 65 Heating circuit with mixing valve, may be low temperature heating circuit (underfloor heating or radiators) |
| 25 Domestic hot water tank exchanger primary outlet | 93 Heating pump for underfloor heating circuit |
| 26 DHW load pump | 117 Three-way mixing valve |
| 27 Non-return valve | 123 Cascade return sensor |
| 30 Calibrated and sealed safety unit | 124 Cascade flow sensor |
| 30e Drain valve | |
| 31 Independent domestic hot water tank | |
| 33 Domestic hot water temperature sensor | |



For more information, see

Electrical connection: Boilers in cascade + 1 direct circuit + 1 underfloor heating circuit + 1 domestic hot water tank, page 51

5.6.4 Connection diagram: controlling a boiler in 0-10 V

Fig.32 Boiler in 0-10 V

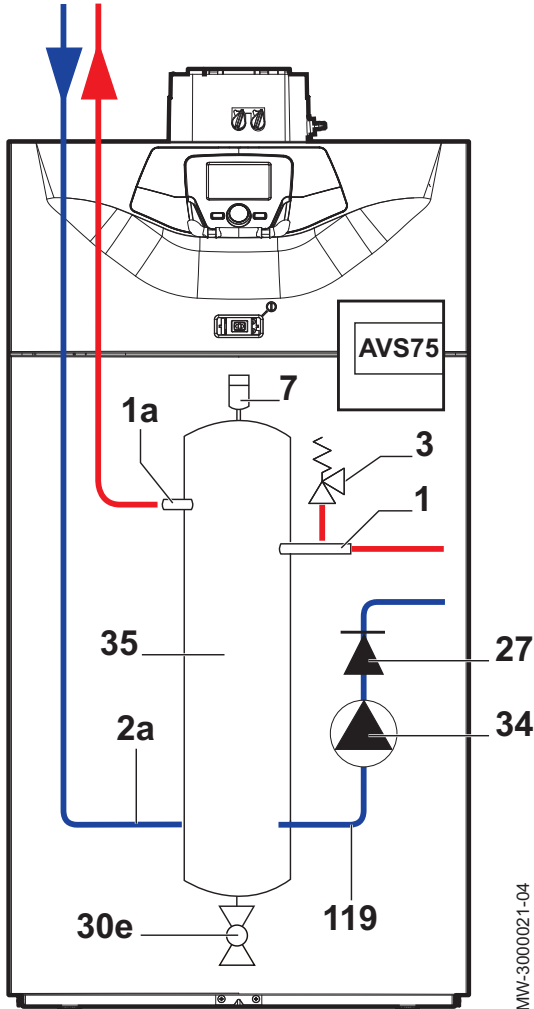

- 1 Boiler flow
- 1a Heating flow
- 2a Heating return
- 3 4 bar (0.4 MPa) safety valve
- 7 Automatic air vent
- 27 Non-return valve
- 30e Drain valve
- 34 Modulating boiler pump
- 35 Low-loss header (optional)
- 119 Boiler return

MW-3000021-04

6 Installation

6.1 General

Installation must be carried out in accordance with the prevailing regulations, codes of practice and the recommendations in this manual.

6.2 Preparation

6.2.1 Accessing the internal boiler components

Fig.33 Removing the front panel

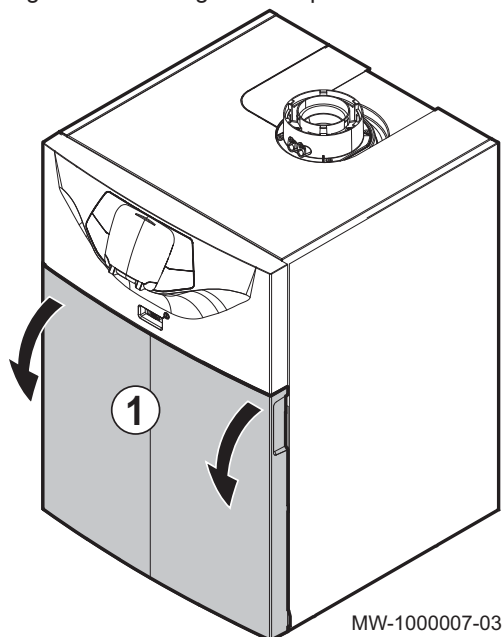
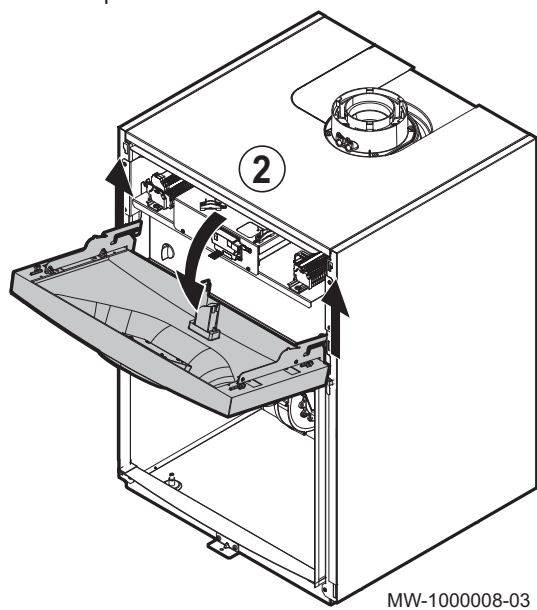

Fig.34 Tilting the panel holding the control panel



1. Remove the front panel by pulling firmly on the notches provided.

2. Lift and tilt the panel holding the control panel

Fig.35 Earth wire

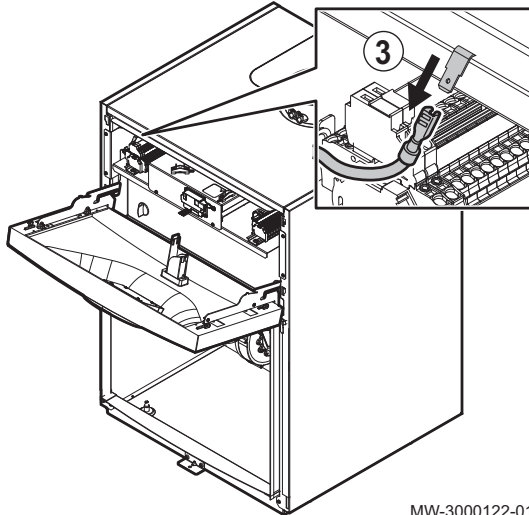

MW-3000122-01

3. Disconnect the earth wire.

Fig.36 Removing the top panel

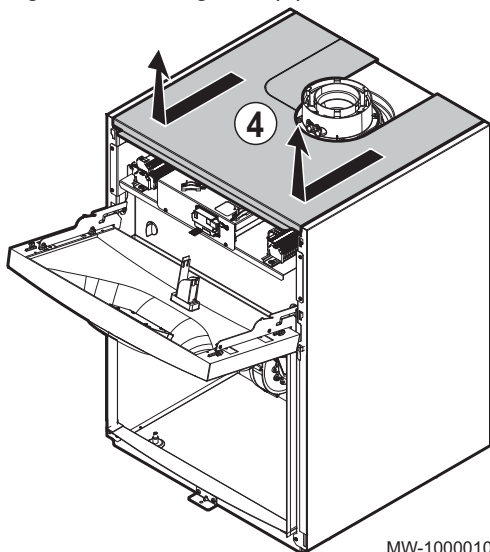

MW-1000010-05

4. Pull and lift the top panel.

Fig.37 Unhooking the panel holding the control panel

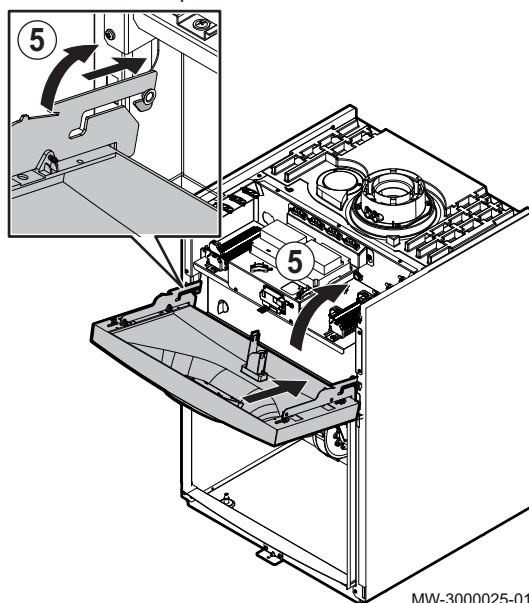

MW-3000025-01

5. Unhook the panel holding the control panel to place it on the boiler.

Fig.38 Location of the disassembly instructions

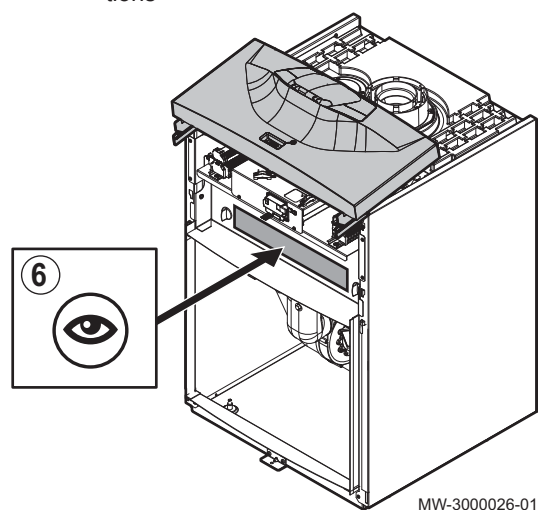

- Remove the detachable panel if necessary.



See

The disassembly instructions can be found on the detachable panel.

6.3 Water connections

6.3.1 Connection of the heating circuit

Abide by the mountings shown in the hydraulic diagrams.



Caution

- The heating pipe must be mounted in accordance with the provisions applicable.
- If installing isolation valves, position the fill/drain valve and the expansion vessel between the isolation valves and the boiler.
- Always install a safety valve calibrated to 4 bar on the heating circuit. The safety valve can be connected to a venting pot. The safety valve must not be used to drain the heating circuit.



See

In the case of an assembly with a low-loss header, use the assembly instructions for the low-loss header. If using a cascade kit, use the assembly instructions for the cascade kit.



Note

The pipes are not provided.

Fig.39 Connecting the "heating circuit flow" pipe

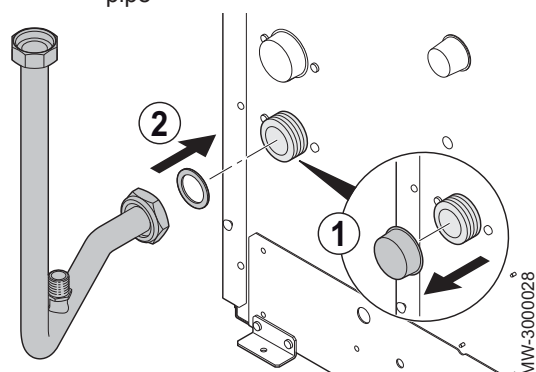

- Remove the anti-dust plug located on the boiler's "heating flow" outlet.
- Connect the "heating circuit flow" pipe to the boiler's "heating flow" outlet.

Fig.40 Mounting the fill and drain valves

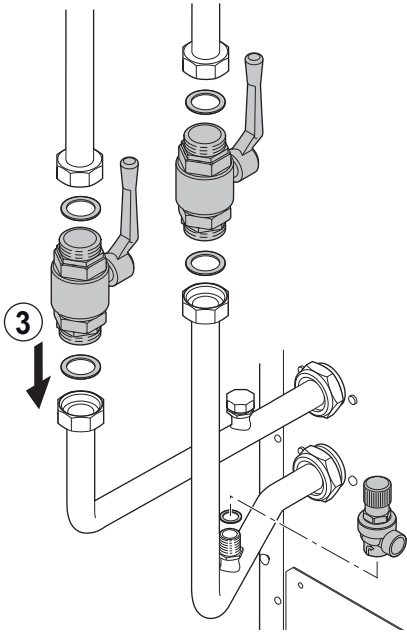

MW-3000029-03

3. Mount the fill and drain valves to the boiler's inlet and outlet (valves not provided).



Note

To facilitate maintenance work, we recommend mounting an isolation valve on the heating flow and return pipes.



Caution

Position the safety valve between the boiler and the isolation valve.

Fig.41 Connecting the "heating circuit return" pipe

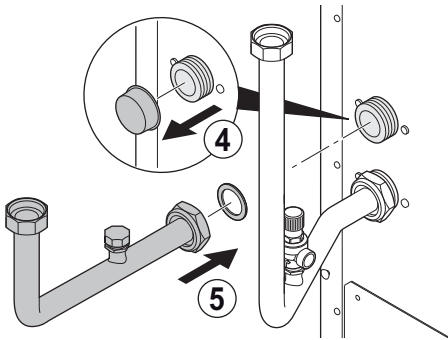

MW-3000030-02

4. Remove the anti-dust plug on the "heating return" inlet.
5. Connect the "heating circuit return" pipe to the boiler's "heating return" inlet.

Fig.42 Mounting the circulation pump

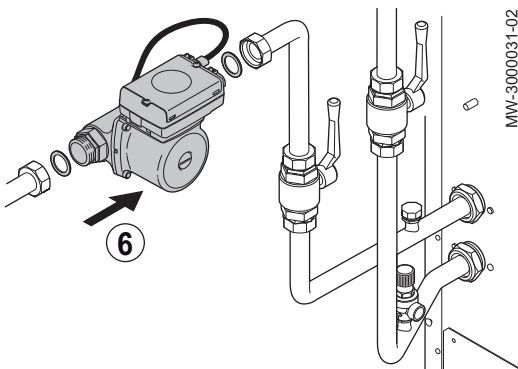

MW-3000031-02

6. Mount the circulation pump on the "heating return" pipe (circulation pump not provided).

6.3.2 Connecting the expansion vessel

1. Determine the volume of the expansion vessel according to the volume of water in the heating circuit.
2. Connect the expansion vessel to the heating circuit return pipe.

■ Volume of the expansion vessel on the heating circuit

Tab.14 Volume of the expansion vessel in relation with the volume of heating circuit

Initial pressure of the expansion vessel	Volume of the installation (in litres)							
	100	125	150	175	200	250	300	> 300
50 kPa (0.5 bar)	4.8	6.0	7.2	8.4	9.6	12.0	14.4	Volume of the installation x 0.048
100 kPa (1 bar)	8.0	10.0	12.0	14.0	16.0	20.0	24.0	Volume of the installation x 0.080
150 kPa (1.5 bar)	13.3	16.6	20.0	23.3	26.6	33.3	39.9	Volume of the installation x 0.133

Terms and conditions of validity:

- Safety valve calibrated to 0.4 MPa (4 bar).
- Average water temperature: 70°C.
- Heating circuit flow temperature: 80°C.
- Heating circuit return temperature: 60°C.
- Filling pressure in the system lower than or equal to the initial pressure in the expansion vessel.

6.3.3 Connecting the condensate discharge pipe

The condensate discharge pipe is located inside the boiler.

- Do not block the condensate discharge pipe.
- Set the discharge pipe at a gradient of at least 30 mm per metre, maximum horizontal length 5 metres.
- Do not drain condensation water into a roof gutter.
- Connect the condensate discharge pipe in accordance with prevailing standards.
- It is preferable to use the condensate neutralisers recommended by the manufacturer of the boiler.

1. Connect a plastic hose to the condensate discharge outlet (DN18).
2. Insert the other end of the hose into a waste water discharge outlet.



For more information, see

Unpacking and initial preparation, page 30

Fig.43 Mounting the hose on the condensate discharge outlet

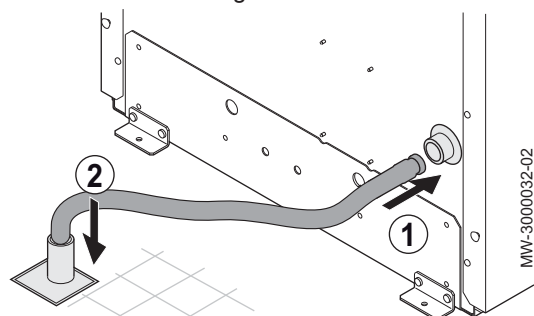

6.4 Gas connection



Warning

Close the main gas valve before starting work on the gas pipes.

The gas pipes are not provided.



Danger

The diameters of the pipes must be defined in accordance with the standards in force in your country.

1. Remove the anti-dust plug located on the boiler's gas inlet.
2. Mount a gas stop valve (not provided) on the boiler's gas inlet.
3. Connect the gas inlet pipe to the gas stop valve.

**Caution**

- Ensure that there is no dust in the gas pipe.
- Connect the gas pipe in accordance with prevailing standards and regulations.



For more information, see
Gas supply, page 25

6.5 Air supply/flue gas connections

6.5.1 Classification

The discharge and intake pipes must be certified for the appropriate configuration and must meet the requirements of the prevailing installation standards in the country.

The pipes must deliver a maximum pressure drop in compliance with the values given in the table below.

Tab.15 Configurations and recommendations for the flue system

Configuration	Description										
B ₂₃ – B _{23P}	<ul style="list-style-type: none"> • Connection to a chimney using a connection kit (single pipe in a flue, combustion air taken from the boiler room). • The maximum pressure drop in the pipes ΔP must not exceed the values given in the table below. The pipes must be certified for this type of use and for a temperature in excess of 100°C. <p>Tab.16 Maximum pressure drop</p> <table border="1"> <thead> <tr> <th>Model</th> <th>Maximum pressure drop ΔP (Pa)</th> </tr> </thead> <tbody> <tr> <td>POWER HT+ 1.50</td> <td>200</td> </tr> <tr> <td>POWER HT+ 1.70</td> <td>200</td> </tr> <tr> <td>POWER HT+ 1.90</td> <td>200</td> </tr> <tr> <td>POWER HT+ 1.110</td> <td>200</td> </tr> </tbody> </table>	Model	Maximum pressure drop ΔP (Pa)	POWER HT+ 1.50	200	POWER HT+ 1.70	200	POWER HT+ 1.90	200	POWER HT+ 1.110	200
Model	Maximum pressure drop ΔP (Pa)										
POWER HT+ 1.50	200										
POWER HT+ 1.70	200										
POWER HT+ 1.90	200										
POWER HT+ 1.110	200										
C ₁₃	<ul style="list-style-type: none"> • Air/flue gas connection using concentric pipes to a horizontal terminal (so-called forced flue). • The terminal parts of the singled-up discharge pipe must be scheduled inside a 50 cm square. 										
C ₃₃	<ul style="list-style-type: none"> • Air/flue gas connection using concentric pipes to a vertical terminal (roof outlet). • The terminal parts of the singled-up discharge pipe must be scheduled inside a 50 cm square. 										
C ₄₃	<ul style="list-style-type: none"> • Air/flue gas connection to a collective flue for sealed boilers. • The chimney or flue gas pipe must be suitable for such use. 										
C ₅₃	<ul style="list-style-type: none"> • Separate air/flue gas connection using a bi-flow adapter. • The terminal parts of combustion air intake and combustion product discharge pipes must not be planned on opposite walls of the building. 										
C ₆₃	<ul style="list-style-type: none"> • The maximum pressure drop in the pipes ΔP must not exceed the values given in the table below. The pipes must be certified for this type of use and for a temperature of more than 100°C. The terminal part of the flue gas pipe must be certified as complying with the EN 1856-1 Standard. • If installing discharge and intake pipes not supplied by Baxi, these must be certified for the type of use scheduled and present a maximum pressure drop in line with the values given in the table below. <p>Tab.17 Maximum pressure drop</p> <table border="1"> <thead> <tr> <th>Model</th> <th>Maximum pressure drop ΔP (Pa)</th> </tr> </thead> <tbody> <tr> <td>POWER HT+ 1.50</td> <td>270</td> </tr> <tr> <td>POWER HT+ 1.70</td> <td>270</td> </tr> <tr> <td>POWER HT+ 1.90</td> <td>320</td> </tr> <tr> <td>POWER HT+ 1.110</td> <td>370</td> </tr> </tbody> </table>	Model	Maximum pressure drop ΔP (Pa)	POWER HT+ 1.50	270	POWER HT+ 1.70	270	POWER HT+ 1.90	320	POWER HT+ 1.110	370
Model	Maximum pressure drop ΔP (Pa)										
POWER HT+ 1.50	270										
POWER HT+ 1.70	270										
POWER HT+ 1.90	320										
POWER HT+ 1.110	370										

Configuration	Description
C ₈₃	<ul style="list-style-type: none"> • Flue gas connection to a collective flue for sealed boilers. The air supply is individual via a terminal coming from outside the building. • The chimney or flue gas pipe must be suitable for such use.



Caution



Note

- Only original components are authorised for connection to the boiler and for the terminal.
- The clear section must comply with the standard.
- The chimney must be swept before installing the discharge flue.



Caution

Ensure that the flue gas discharge pipes are securely attached to the wall with suitable retaining flanges to prevent any damage and guarantee the tightness of every gasket in the circuit.



Caution

The minimum gradient of the condensates discharge pipe from the boiler to the waste water discharge must be 1 cm per linear metre.

6.5.2 Coaxial pipes

Fig.44 Specifications of the coaxial pipes for POWER HT+ 1.50 and POWER HT+ 1.70

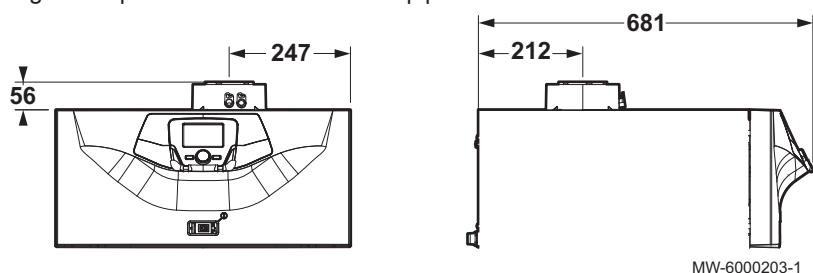
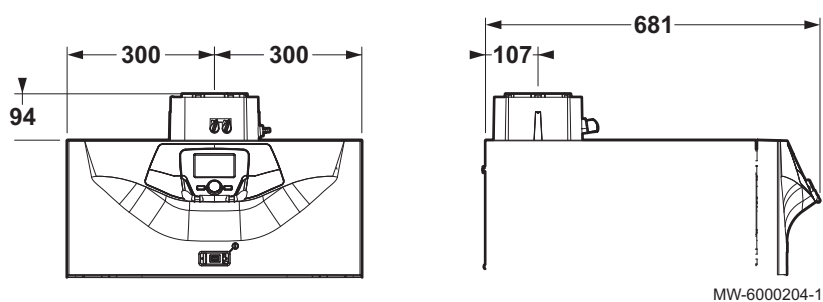

Fig.45 Specifications of the coaxial pipes for POWER HT+ 1.90 and POWER HT+ 1.110



This type of pipe is used to discharge exhaust gases and draw in combustion air, whether outside the building or in the flue gas pipes. The 90° coaxial elbow is used to connect the boiler to the discharge/intake pipes in every direction due to the 360° rotation option. It can also be used as an extra elbow in combination with the coaxial pipe or the 45° elbow. If discharging to the outside, the discharge/intake pipe must stick out of the wall by at least 18 mm to allow fitting of the aluminium rosette and its sealing unit and thus prevent any infiltration of water.

- Insertion of a 90° elbow reduces the total length of the pipe by 1 metres.
- Insertion of a 45° elbow reduces the total length of the pipe by 0.5 metres.
- The first 90° elbow is not taken into account in calculating the maximum length available.

6.5.3 Pipes in cascade (not provided)

These types of pipes are used to discharge the combustion products from several boilers interlinked in cascade via a shared flue gas collector. The collector must be used solely to connect the boilers to the flue gas pipe. The diameters available are 150 mm and 200 mm.

Tab.18 Flue system for boilers in cascade

Boiler model	Maximum number of boilers in cascade		
	Diameter 125 mm (200 kW max)	Diameter 160 mm (250 kW max)	Diameter 200 mm (500 kW max)
POWER HT+ 1.50	4	5	10
POWER HT+ 1.70	2	3	7
POWER HT+ 1.90	/	2	5
POWER HT+ 1.110	/	2	4



Caution

For this type of extraction, each boiler must be fitted with a flue gas valve (non-return valve) Ø 110/110 mm.



Caution

The calculation of the length of the flue gas pipe must be made by a qualified technician during the system design phase, in accordance with the requirements of the prevailing standards.

6.5.4 Lengths of the air/flue gas pipes



Warning

The discharge and intake pipes must be certified for the appropriate configuration and their pressure drops must comply with the values given in the following corresponding table(s).

■ **Configuration B_{23p}**

- Ventilation of the premises: in accordance with the NFP 45 – 204 or DTU 61.1 standard.
- Lengths L1, L2 and L3 are obtained with Centrotec pipes covered by CE marking and the TAD Technical Application Directive.

Fig.46 Flexible flue gas system B_{23p}

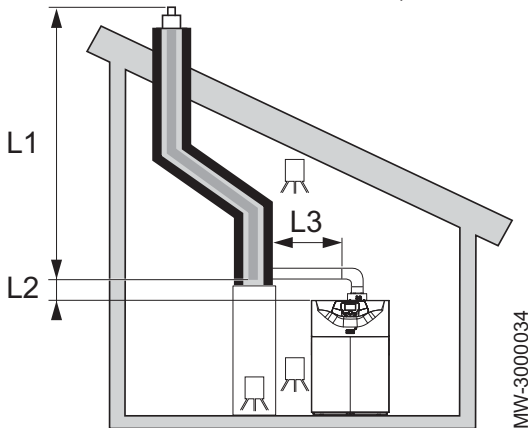
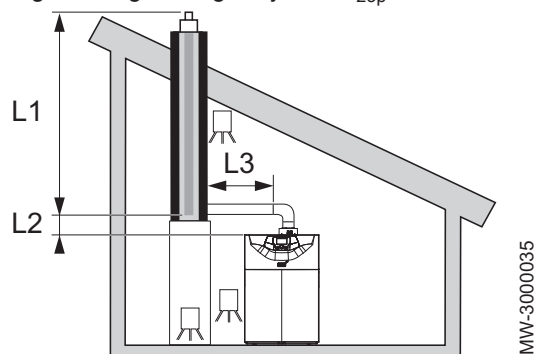
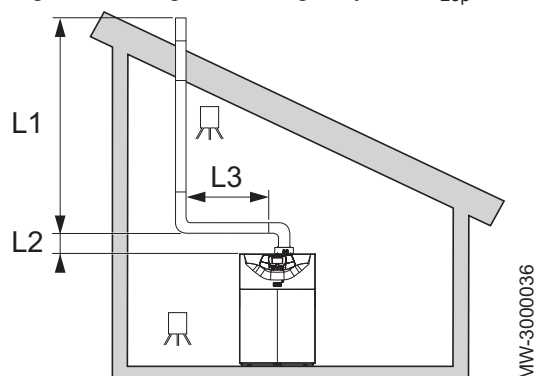

Fig.47 Rigid flue gas system B_{23p}Fig.48 Through-roof flue gas system B_{23p}

i **Note**
For B_{23p} configurations, the lengths given in the tables are valid for horizontal pipes with a maximum length of 1 metre. For each additional metre of horizontal pipe, subtract 1.2 m from the vertical length L_{max}.

Tab.19 Flue gas system connection type B_{23p}

Arrangement	Configuration	Unit	POWER HT+ 1.50		POWER HT+ 1.70		POWER HT+ 1.90		POWER HT+ 1.110		
			Ø 80	Ø 110	Ø 80	Ø 110	Ø 110	Ø 125	Ø 110	Ø 125	Ø 160
L3<2m + 2 el-bows	(L1 + L2) rigid	m	20	56	8	56	20	56	56	56	–
L3<2m + 2 el-bows	(L1 + L2) flexible	m	15	56	6	38	–	21	15	–	–
L3<5m + 2 el-bows	(L1 + L2) rigid	m	–	56	–	56	24	56	–	43	56
L3<5m + 2 el-bows	(L1 + L2) flexible	m	–	56	–	38	13	–	–	–	–

■ Configuration C₁₃

i **Note**
Pipes subject to technical evaluation 14 08–1289.

Fig.49 Maximum length of the connections

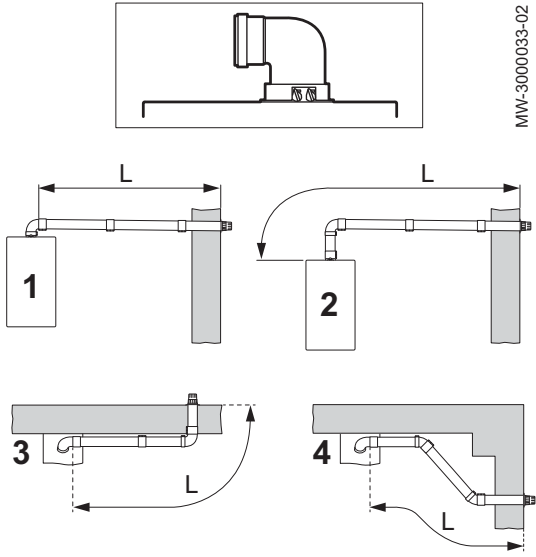

Tab.20 Maximum length for configuration C₁₃

Configuration	Unit	POWER HT+ 1.50	POWER HT+ 1.70	POWER HT+ 1.90	POWER HT+ 1.110
		Ø 80 / Ø 125	Ø 80 / Ø 125	Ø 110 / Ø 160	Ø 110 / Ø 160
1	m	L<10 m	L<10 m	L<10 m	L<10 m
2	m	L<10 m	L<10 m	L<10 m	L<10 m
3	m	L<9 m	L<9 m	L<9 m	L<9 m
4	m	L<9 m	L<9 m	L<9 m	L<9 m

■ Configuration C₃₃

i Note
Pipes subject to technical evaluation 14 08–1289.

Fig.50 Maximum length of the connections

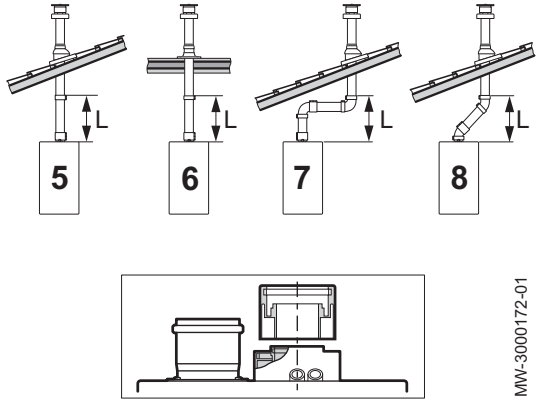

Tab.21 Maximum length for configuration C₃₃

Configuration	Unit	POWER HT+ 1.50	POWER HT+ 1.70	POWER HT+ 1.90	POWER HT+ 1.110
		Ø 80 / Ø 125	Ø 80 / Ø 125	Ø 110 / Ø 160	Ø 110 / Ø 160
5	m	L<10 m	L<10 m	L<10 m	L<10 m
6	m	L<10 m	L<10 m	L<10 m	L<10 m
7	m	L<8 m	L<8 m	L<8 m	L<8 m
8	m	L<9 m	L<9 m	L<9 m	L<9 m

■ Configuration C₅₃

i Note
Pipes subject to technical evaluation 14 08–1289.

Fig.51 Maximum length of the connections

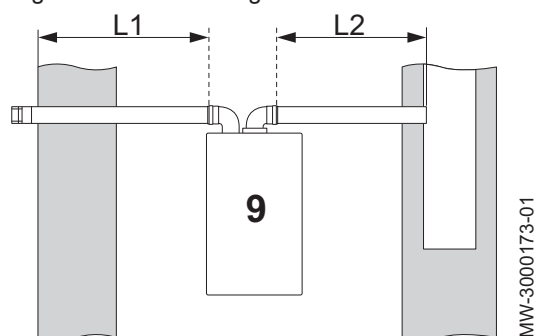
Tab.22 Maximum length for configuration C₅₃

Configuration	Unit	POWER HT+ 1.50	POWER HT+ 1.70	POWER HT+ 1.90	POWER HT+ 1.110
	mm	Ø 80 / Ø 125	Ø 80 / Ø 125	Ø 110 / Ø 160	Ø 110 / Ø 160
9	m	L1<15 m and L1+L2<60 m (Ø 80)	L<15 m and L1+L2<30 m (Ø 80)	L1<7 m and L1+L2<27 m (Ø 110)	L1<7 m and L1+L2<27 m (Ø 110)

6.6 Electrical connections

6.6.1 Recommendations

- Earth the appliance before making any electrical connections.
- Only qualified engineers may carry out electrical connections, always with the power off.
- Power the appliance via a circuit that includes an omnipolar switch with contact opening distance of 3 mm or more.
- When making electrical connections to the mains, respect the polarities.



Danger

Position the various electrical cables in such a way that they never touch the heating pipes.

Keep the various electrical cables far enough from the heating pipes so that they cannot be damaged by the effect of the heat.

6.6.2 Recommended cable cross section

The cable will be carefully chosen according to the following information:

- Distance of the appliance from the power source.
- Upstream protection.
- Neutral operating conditions.

Tab.23 Specifications of the power cable and the power source

Cable cross section (mm ²)	3 x 1.5
Curve C (circuit breaker)	10 A

6.6.3 Accessing the terminal blocks

1. Remove the front panel.



For more information, see

Accessing the internal boiler components, page 35

6.6.4 Wiring the terminal blocks

Use a flat-bladed screwdriver less than 3.5 mm in width.

Fig.52 Pressing down the spring

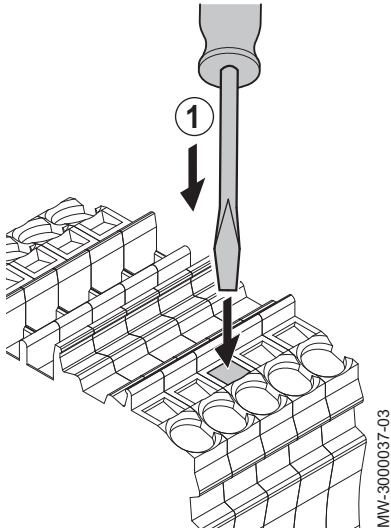

Fig.53 Connecting the wire

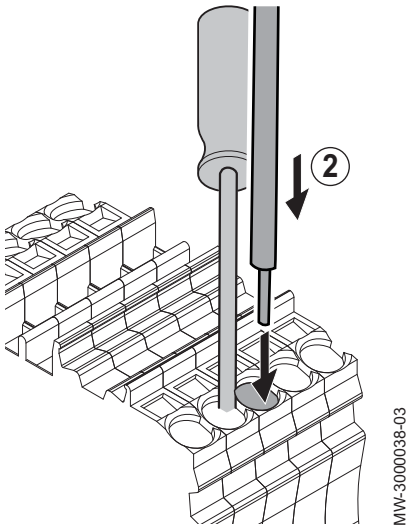
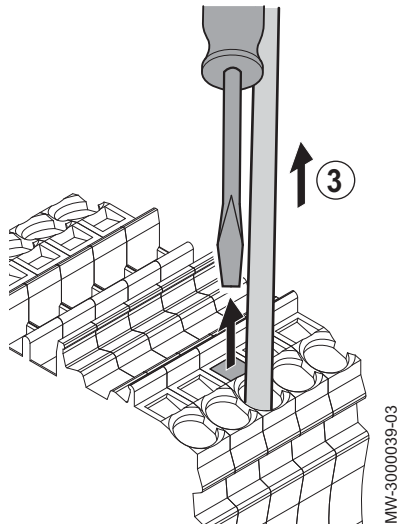

Fig.54 Attaching the wire



1. Press down the spring on the terminal block with a suitable screwdriver.

2. Insert the stripped part of the wire into the corresponding connector.



Caution

The length to be stripped must be between 10 and 12 mm.

3. Release the pressure on the spring. The wire is attached.

6.6.5 Description of the power supply terminal block

Fig.55 Power supply terminal block

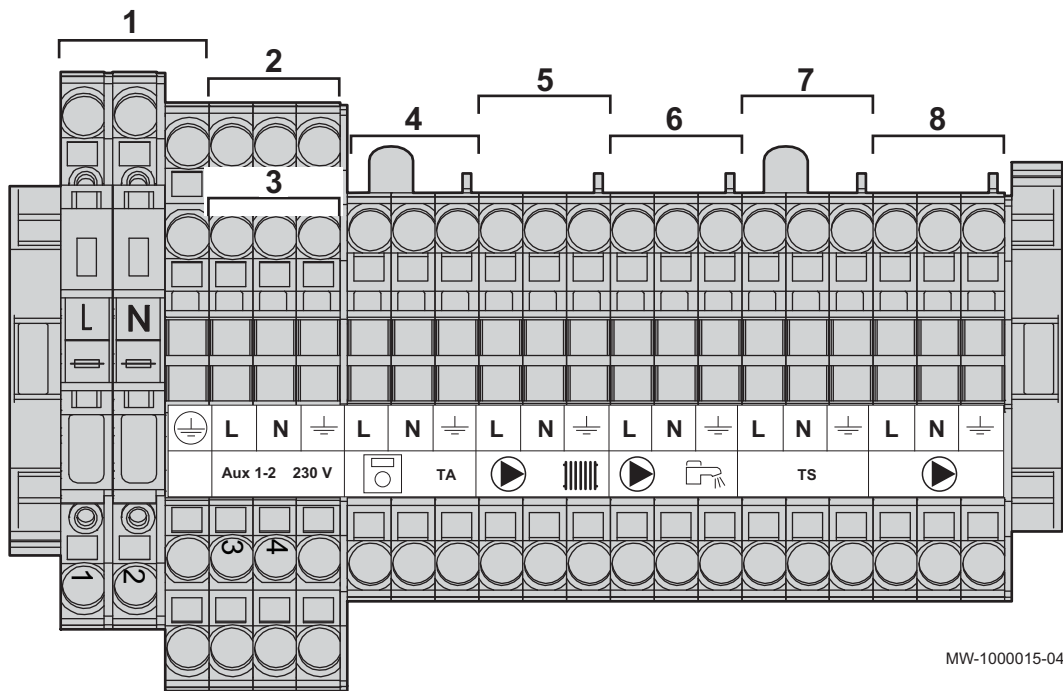

- | | | | |
|---|----------------------------------|---|-------------------------|
| 1 | Power supply 230 V 50 Hz | 5 | Heating circuit pump |
| 2 | Power supply auxiliary circuit 1 | 6 | Domestic hot water pump |
| 3 | Power supply auxiliary circuit 2 | 7 | Safety contact |
| 4 | Room thermostat | 8 | Boiler pump |



Caution

All connections are made to the terminal blocks provided for that purpose in the boiler connection box. The output available per outlet is 180 W (1 A, with $\cos \phi = 0.8$) and the inrush current must be less than 5 A. If the load exceeds either of these values, the control must be relayed using a contactor that must not be installed in the control panel under any circumstances. The sum of the currents from all outlets must not exceed 4 A.

6.6.6 Description of the sensor terminal block

Fig.56 Sensor terminal block

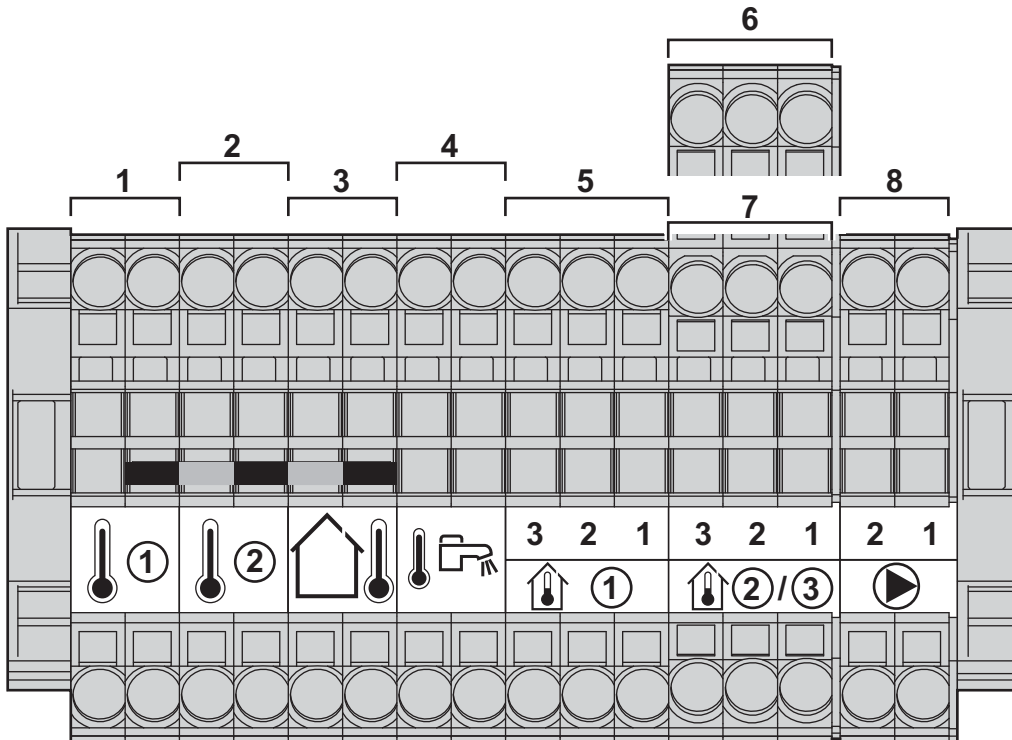

MW-1000016-04

- | | |
|-----------------------------|--------------------------------|
| 1 Auxiliary sensor 1 - BX1 | 5 Room temperature sensor 1 |
| 2 Auxiliary sensor 2 - BX2 | 6 Room temperature sensor 2 |
| 3 Outside sensor | 7 Room temperature sensor 3 |
| 4 Domestic hot water sensor | 8 Boiler pump modulation (PWM) |

6.6.7 Electrical connection: 1 boiler + 1 direct circuit + 1 domestic hot water tank

Fig.57 1 boiler + 1 direct circuit + 1 domestic hot water tank

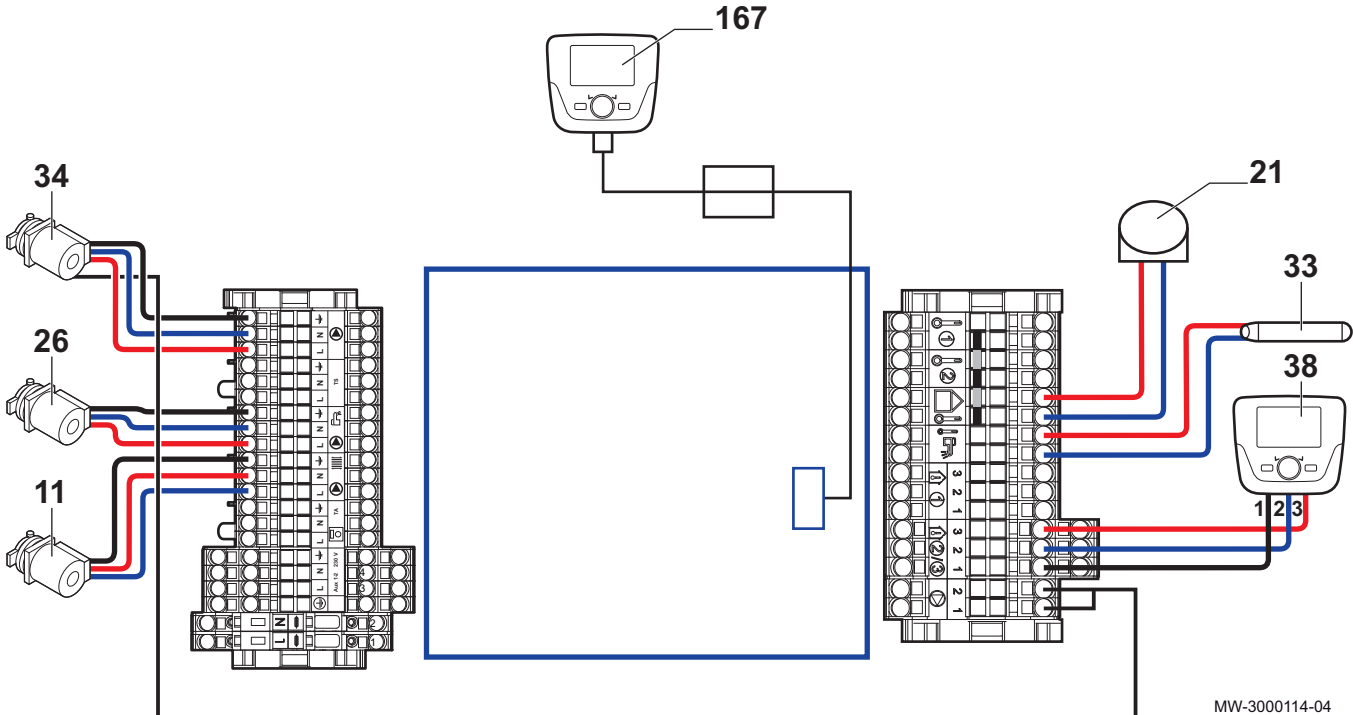

- 11 Heating pump
- 21 Outside temperature sensor
- 26 DHW load pump
- 33 Domestic hot water temperature sensor
- 34 Primary pump
- 38 Remote control
- 167 Boiler control panel



For more information, see
 Connection diagram: 1 boiler + 1 direct circuit + 1 domestic hot water tank, page 31

6.6.8 Electrical connection: 1 boiler + 1 direct circuit + 1 under-floor heating circuit + 1 domestic hot water tank

Fig.58 1 boiler + 1 direct circuit + 1 underfloor heating circuit + 1 domestic hot water tank

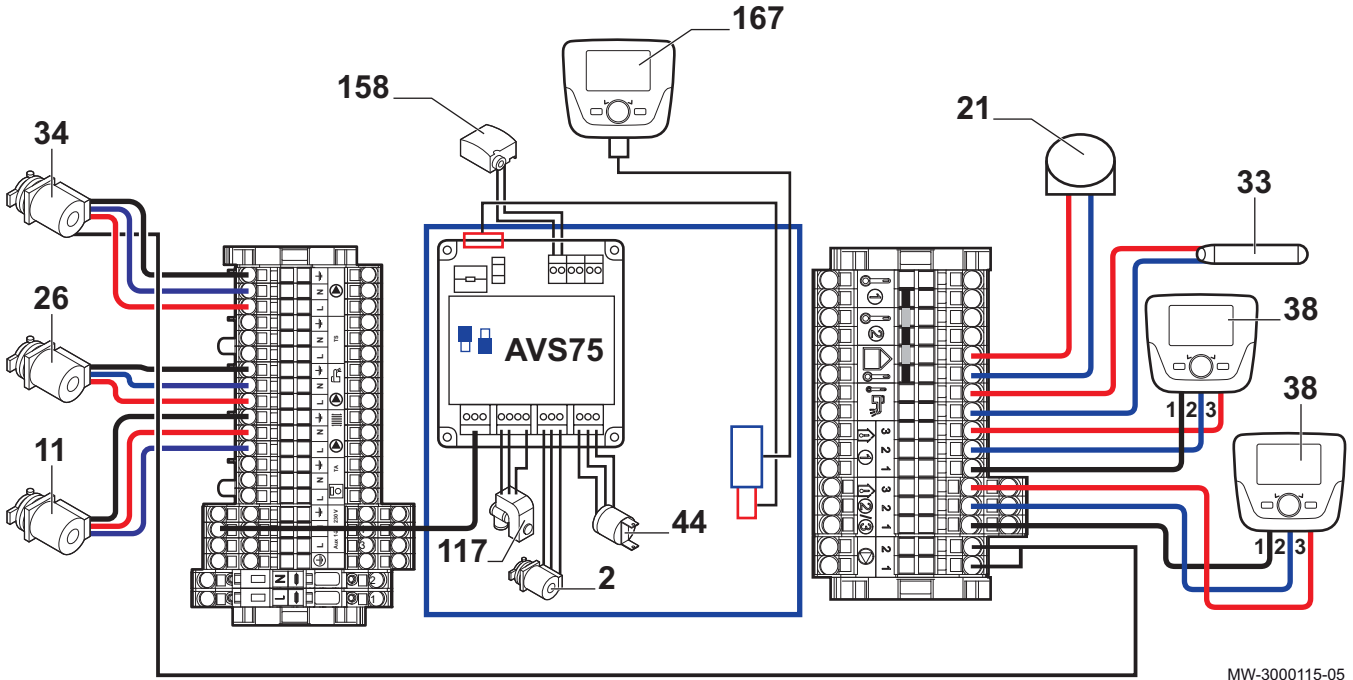

- 2 Heating pump
- 10 Three-way mixing valve
- 11 Heating pump
- 21 Outside temperature sensor
- 26 DHW load pump
- 33 Domestic hot water temperature sensor
- 34 Primary pump
- 38 Room temperature sensor
- 44 65°C safety thermostat with manual reset for under-floor heating (DTU 65.8, NF P52-303-1)
- 167 Boiler control panel
- 158 Flow temperature sensor



For more information, see

Configuring an installation with 1 boiler + 1 low-loss header + 1 direct circuit + 1 underfloor heating circuit + 1 domestic hot water tank, page 55
 Connection diagram: 1 boiler + 1 direct circuit + 1 underfloor heating circuit + 1 domestic hot water tank, page 32

6.6.9 Electrical connection: controlling a boiler in 0-10 V

Fig.59 Controlling a boiler in 0-10 V

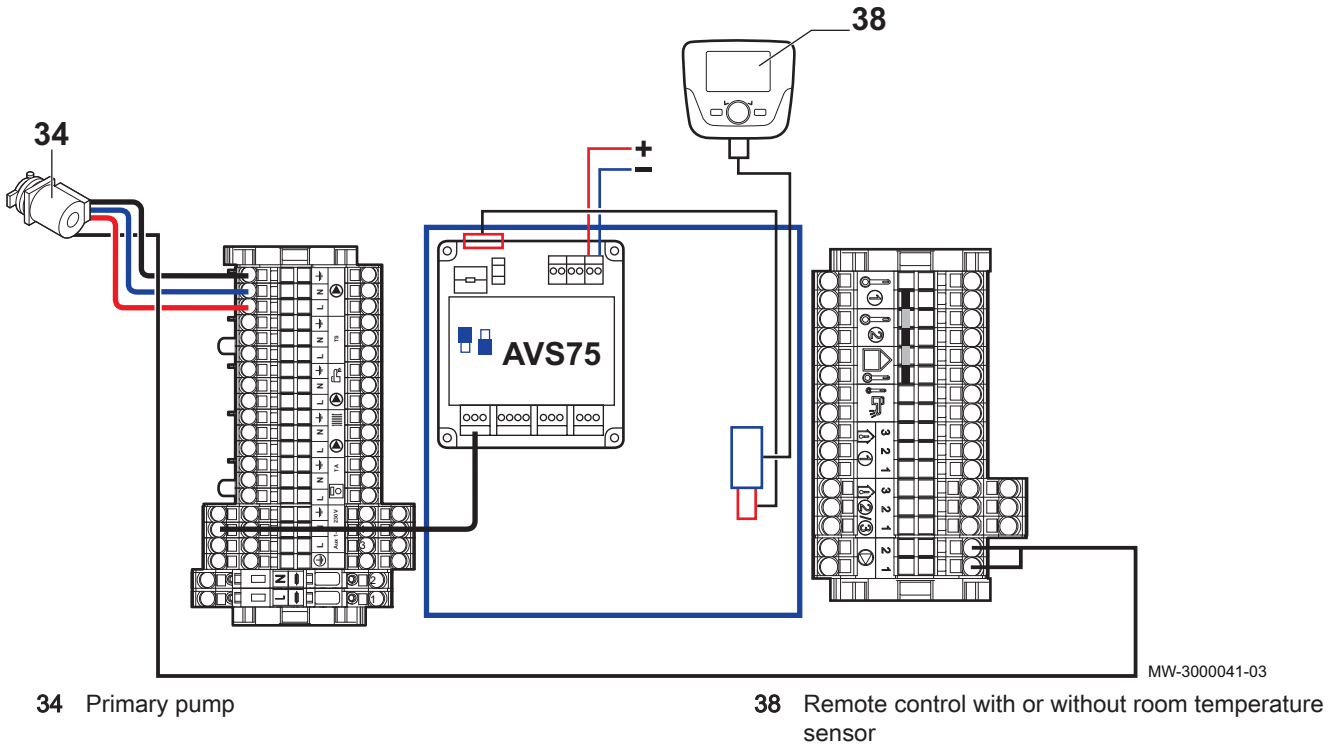



For more information, see
 Connection diagram: controlling a boiler in 0-10 V, page 34
 Configuring control of a boiler in 0-10 V, page 56

6.6.10 Electrical connection: Boilers in cascade + 1 direct circuit + 1 underfloor heating circuit + 1 domestic hot water tank

Fig.60 Boilers in cascade + 1 direct circuit + 1 underfloor heating circuit + 1 domestic hot water tank

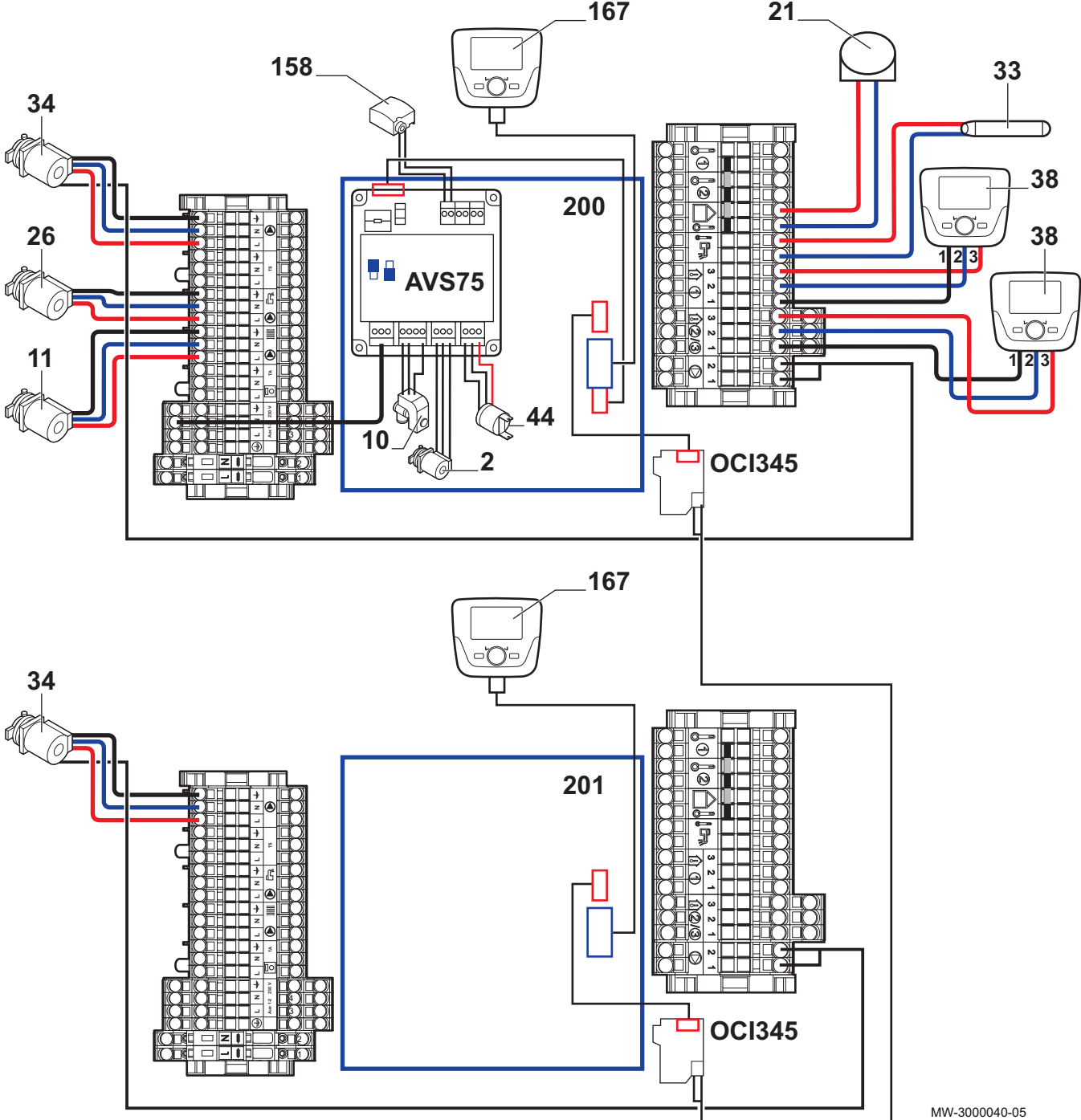

MW-3000040-05

- | | |
|--|-----------------------------|
| 2 Heating pump | 38 Room temperature sensor |
| 10 Three-way mixing valve | 44 |
| 11 Heating pump | 158 Flow temperature sensor |
| 21 Outside temperature sensor | 167 Boiler control panel |
| 26 DHW load pump | 200 Lead boiler |
| 33 Domestic hot water temperature sensor | 201 Slave boiler |
| 34 Primary pump | |



For more information, see

Connection diagram: Boilers in cascade + 1 direct circuit + 1 underfloor heating circuit + 1 domestic hot water tank, page 33
 Configuring boilers in cascade + 1 direct circuit + 1 underfloor heating circuit + 1 domestic hot water tank, page 55

6.6.11 Connecting boilers in cascade with a module OCI 345

Connect the boilers included in the boiler cascade with **OCI 345** modules (electronic devices that handle communication through a **BUS** link). The **OCI 345** modules must be connected to each boiler with three connectors.

Tab.24 Connecting the boiler components in cascade

Component 1	Component 2
OCI 345 module on the boiler	X30 connector on the boiler PCB. (Flat cable supplied with the OCI 345 module).
MB connector of a OCI 345 module.	MB connector of a OCI 345 module on a boiler.
DB connector of a OCI 345 module.	DB connector of a OCI 345 module on a boiler

Fig.61 Connecting **OCI 345** modules for boilers in cascade

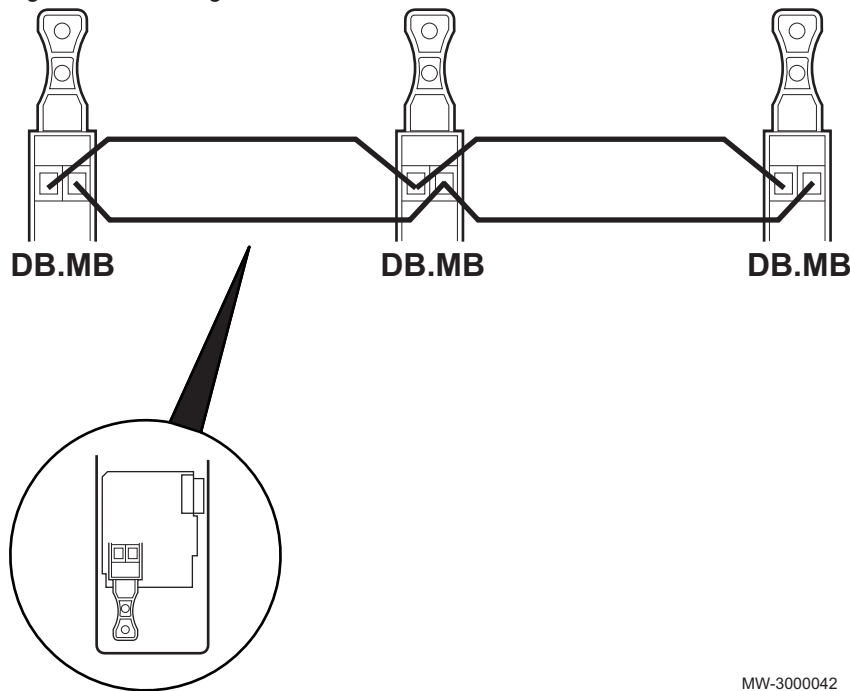

MW-3000042

To make the connections between the various **MB** and **DB** connectors, use a shielded cable with the following specifications:

Type	Cross section	Maximum length
HAR H05 VV-F	2 x 1.5 mm ²	200 m

6.7 Filling the system

6.7.1 Filling the heating system

Before filling the heating system, rinse it thoroughly.

1. Fill the heating system until you reach a pressure of between 0.15 and 0.2 MPa (1.5 and 2 bar).
2. Check the tightness of the hydraulic connections.

3. Completely vent the heating circuit for optimum running.



For more information, see
Water treatment, page 24

■ Flushing new systems and systems less than 6 months old

1. Clean the installation with a powerful universal cleaner to eliminate debris from the appliance (copper, hemp, flux).
2. Thoroughly flush the installation until the water runs clear and shows no impurities.



For more information, see
Water treatment, page 24

■ Flushing an existing installation

1. Remove any sludge from the installation.
2. Flush the installation.
3. Clean the installation with a universal cleaner to eliminate debris from the appliance (copper, hemp, flux).
4. Thoroughly flush the installation until the water runs clear and shows no impurities.



For more information, see
Water treatment, page 24

6.7.2 Filling the siphon

1. Clean the siphon.
2. Completely fill the siphon until it overflows.



Danger

Fill the siphon to the top. If the siphon is empty, there is a danger of intoxication by exhaust gases.



For more information, see
Cleaning the siphon, page 102

6.8 Completing installation

1. Reconnect the earth wire and put the front panel back in place.
2. Discard the various packaging items.
3. Affix the data plate found in the instructions bag to a visible part of the boiler.



For more information, see
Data plate, page 28

7 Commissioning

7.1 General

Commissioning the boiler is done for first time use, after a prolonged shut-down (more than 28 days) or after any event that would require complete re-installation of the boiler. Commissioning of the boiler allows the user to review the various settings and checks to be made to start up the boiler in complete safety.

7.2 Check-list before commissioning

1. Check that the gas type supplied matches the data shown on the boiler's data plate.



Warning

Do not commission the boiler if the gas supplied does not match the gas types approved for the boiler.

2. Check connection of the earth wires.
3. Check the tightness of the gas circuit from the non-return valve to the burner.
4. Check the hydraulic circuit from the boiler's isolation valves to the connection to the heating body.
5. Check the hydraulic pressure in the heating system.
6. Check the electricity supply connections to the various boiler components.
7. Check the electrical connections on the thermostat and the other external components.
8. Check the ventilation in the room in which the system is installed.
9. Check the flue gas connections.
10. Test the boiler at full load.
11. Test the boiler at part load.



For more information, see

Setting the air/gas ratio (maximum heat input), page 0
Setting the air/gas ratio (reduced heat input), page 0

7.3 Commissioning procedure

7.3.1 First time commissioning

When commissioning the boiler for the first time, the control panel needs to be synchronised with the boiler. The default setting for the control panel is English.

1. Press the  button for 5 seconds.
Synchronisation between the boiler and the control panel is running and shows its progress from 1% to 100%. Synchronisation may take several minutes.
2. Select the language.
3. Set the date and time.



For more information, see

Setting the date and time, page 75
Language Selection, page 76

7.3.2 Checking the gas inlet



Danger

Ensure that the boiler is switched off.

1. Open the main gas valve.
2. Open the gas valve on the boiler.
3. Open the front panel.

4. Check the gas supply pressure at the pressure outlet on the gas valve unit.
5. Check the tightness of the gas connections made after the gas valve unit in the boiler.
6. Check the tightness of the gas pipe, including any valves, from the non-return valve to the burner. The test pressure must not exceed 0.06 bar (0.006 MPa).
7. Vent the gas supply pipe by unscrewing the pressure outlet on the gas valve unit. Close the outlet again when the pipe has been sufficiently vented.
8. Check the tightness of the gas connections in the boiler.



For more information, see
 Stopping the boiler, page 59
 Gas valves, page 0

7.3.3 Checking the electrical connections

1. Check the electrical connection to the mains.
2. Check the connection and positioning of the sensors.
3. Check the connection of the circulating pump(s).
4. Check the connection of the optional equipment.
5. Check the length of the cables and that they are firmly secured in the cable clamps.

7.3.4 Checking the hydraulic circuit

1. Check the siphon, which must be completely filled with water.
2. Check that there are no leaks on the boiler's hydraulic connections.
3. Check the pressure in the expansion vessel before filling the system.

7.4 Configuring the system

7.4.1 Configuring an installation with 1 boiler + 1 low-loss header + 1 direct circuit + 1 underfloor heating circuit + 1 domestic hot water tank

1. Access the installer parameters
2. Set the following parameters on the boiler:

Tab.25 Boiler settings

Parameter number	Parameter	Setting
5715	Temps / mode CH2	On
6020	Function extension module 1	Temps / mode CH2
6024	Funct input EX21 module 1	Limit thermostat CH



For more information, see
 Electrical connection: 1 boiler + 1 direct circuit + 1 underfloor heating circuit + 1 domestic hot water tank, page 49
 Connection diagram: 1 boiler + 1 direct circuit + 1 underfloor heating circuit + 1 domestic hot water tank, page 32
 Modifying the installer parameters, page 58
 List of installer parameters, page 64
 Configuring an installation with 1 boiler + 1 low-loss header + 1 direct circuit + 1 underfloor heating circuit + 1 domestic hot water tank, page 55

7.4.2 Configuring boilers in cascade + 1 direct circuit + 1 underfloor heating circuit + 1 domestic hot water tank

1. Go to the installer parameters on boiler 1 (master boiler).
2. Set the following parameters on boiler 1:

Tab.26 Settings on boiler 1 (master boiler)

Parameter number	Parameter	Setting
5710	Temps / mode CH1	On
5715	Temps / mode CH2	On
5731	Sensor input BX2	Common flow sensor B10
5932	Sensor input BX3	Cascade return sensor B70
6020	Function extension module 1	Temps / mode CH2
6600	Device address	1
6640	Clock mode	Master

3. Go to the installer parameters on boiler 2 (slave boiler).
4. Set the following parameters on boiler 2:

Tab.27 Settings on boiler 2 (slave boiler)

Parameter number	Parameter	Setting
5710	Temps / mode CH1	Off
6600	Device address	2
6640	Clock mode	Slave without remote setting

**For more information, see**

Electrical connection: Boilers in cascade + 1 direct circuit + 1 underfloor heating circuit + 1 domestic hot water tank, page 51
 Connection diagram: Boilers in cascade + 1 direct circuit + 1 underfloor heating circuit + 1 domestic hot water tank, page 33
 Connecting boilers in cascade with a module OCI 345, page 52
 Modifying the installer parameters, page 58
 List of installer parameters, page 64

7.4.3 Configuring control of a boiler in 0-10 V

1. Go to the installer parameters.
2. Set the following parameters on the boiler:

Tab.28 Boiler settings

Parameter number	Parameter	Setting
5710	Temps / mode CH1	Off
6020	Function extension module 1	Multifunctional
6046	Function input H2 module 1	Consumer request VK1 10V
6049	Voltage value 1 H2 module 1	0
6050	Funct value 1 H2 module 1	0
6051	Voltage value 2 H2 module 1	10
6052	Funct value 2 H2 module 1	800 ⁽¹⁾

(1) This parameter setting is an example. The value 800 means that, at 10 V, the set point will be 80°C.

**For more information, see**

Connection diagram: controlling a boiler in 0-10 V, page 34
 Electrical connection: controlling a boiler in 0-10 V, page 50
 Modifying the installer parameters, page 58
 List of installer parameters, page 64

7.4.4 Configuring a master boiler and the slave boilers in a cascade

1. Access the installer parameters of the master boiler.
2. Set the following parameters on the master boiler:

Tab.29 Configuration of the master boiler in a cascade

Parameter number	Parameter	Setting	Description
5977	Function input H5	None	Deactivation of the thermostat on terminal block M1 (1-2)
6030	Relay output QX21 module 1	heating pump CH1 Q2	Check on the pump on circuit 1
6040	Sensor input BX21 module 1	Common flow sensor B10	Check on the cascade discharge temperature
6041	Sensor input BX22 module 1	Cascade return sensor B70	Check on the cascade return temperature
6200	Save sensors	Yes	Saving any modifications made. The setting will revert automatically to No immediately after the adjustment.
6630	Cascade master	Always	Identification master boiler
6640	Clock mode	Autonomously	Cascade master boiler clock setting

3. Access the installer parameters of the slave boiler(s):
4. Set the following parameters on the slave boiler(s).

Tab.30 Cascade configuration of the slave boilers

Parameter number	Parameter	Setting	Description
5710	Temps / mode CH1	Off	Deactivation of the thermostat on terminal block M1 (1-2)
6600	Device address	2...3...4...	Cascade activation
6640	Clock mode	Slave with remote setting	Setting the slave boiler clock with a master boiler

8 Operation

8.1 Use of the control panel

Fig.62 Accessing the User parameters

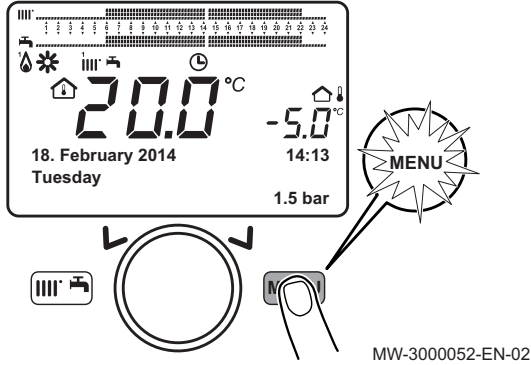

Fig.63 Accessing the User parameters

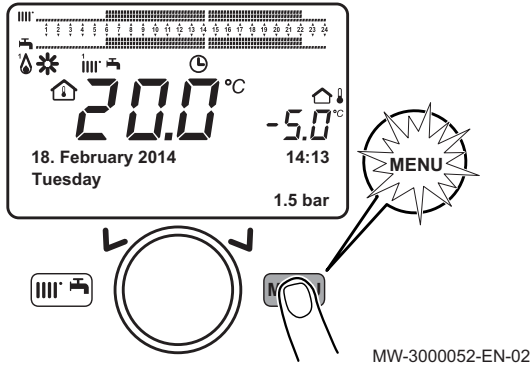
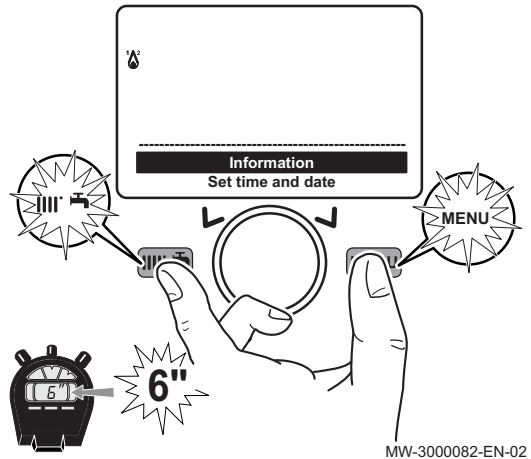

Fig.64 Accessing the installer parameters



8.1.1 Modifying the user parameters

1. Press the key to access the parameters.



Note

Press the key to return to the main display.

The user parameters can now be accessed. Use the button to select and modify them.



For more information, see

List of user parameters, page 62

8.1.2 Modifying the installer parameters

1. Press the key to access the parameters.

2. Press the and keys simultaneously for at least 6 seconds.

Fig.65 Confirming the parameters

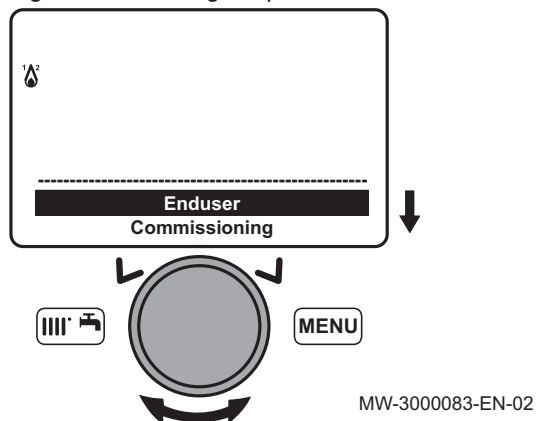
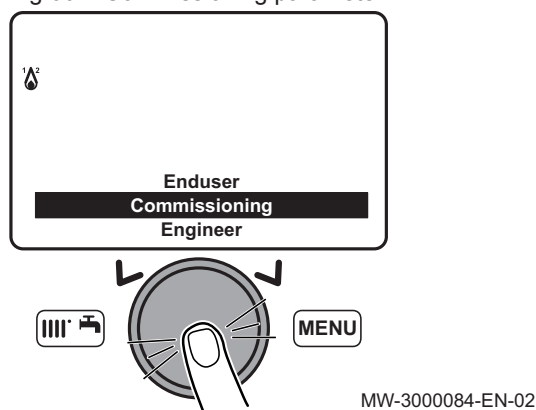

Fig.66 Commissioning parameter



3. Select the **Commissioning** menu by turning the button.

4. Confirm the menu selection by pressing the button .

**Note**

Press the key to return to the main display.

The parameters for the **Commissioning** mode can now be accessed. Use the button to select and modify them.

**For more information, see**

List of installer parameters, page 64

8.2 Starting up the boiler

Fig.67 Putting the boiler into operation

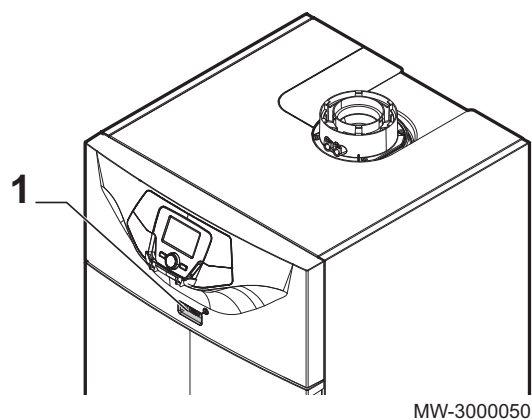

1. Start up the boiler by pressing the ON/OFF switch.
2. Open the gas cock.
3. Press the key to access the shortcuts menu.
4. Select the **Standby/operation** parameter by turning the button.
5. Press the button to start up the boiler. The symbol disappears.

8.3 Stopping the boiler

**Note**

Choose the operating mode **Off** or **Standby**.

1. Switch off the boiler by pressing the ON/OFF switch.
2. Close the gas cock.

8.3.1 Putting the boiler in Standby mode

1. Press the key to access the shortcuts menu.
2. Select the **Standby/operation** parameter by turning the button.
3. Press the button to put the boiler in standby. The symbol is displayed.

8.4 Frost Protection

The electronic management system of the boiler includes protection against frost. If the water temperature falls below 5°C, the burner starts up in order to provide a water temperature of 30°C.

This function only works if the boiler is turned on, the gas supply open and the hydraulic pressure correct.

8.4.1 Activating the Off

Fig.68 Shortcuts menu

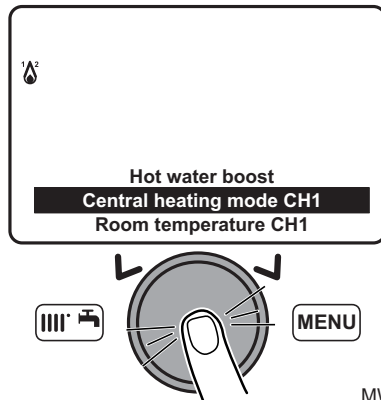

MW-3000051-EN-02

1. Press the key to access the shortcuts menu.
2. Select the parameter **Central heating mode CH1** by turning the button.
3. Confirm the selection by pressing the button.
4. Select the parameter **Off** by turning the button.
5. Confirm the selection by pressing the button.
The symbol is displayed.



Note

When the operating mode **Off** is activated:













- The electrical circuits continue to be powered up.
- The frost protection function is activated.

9 Settings

9.1 List of parameters

9.1.1 Shortcuts menu



Tab.31 Functions accessible with the shortcut key 

Parameter	Description	Adjustment range
Standby/operation	Boiler standby / start-up	<ul style="list-style-type: none"> • Standby : Boiler put on standby. <ul style="list-style-type: none"> - The symbol  is displayed. - The boiler's operating modes are deactivated. - The frost protection function is activated. • On : Putting the boiler into operation
316:Hot water boost	Forcing domestic hot water production.	<ul style="list-style-type: none"> • On : <ul style="list-style-type: none"> - Activates forcing of domestic hot water. - The symbol  is displayed. - If a domestic hot water tank is connected to the boiler circuit, the boiler will give priority to forcing heating of the DHW tank, independently of the other parameters. • Off : Deactivates forcing of domestic hot water.
Central heating mode CH1	Boiler operating mode.	<ul style="list-style-type: none"> • On : <ul style="list-style-type: none"> - Heating is always activated. - The symbols ,  and  are displayed. • Reduced : <ul style="list-style-type: none"> - Heating is deactivated. - The symbols ,  and  are displayed. • Timed : <ul style="list-style-type: none"> - Heating is dependent on the time range programmed. - The symbols  and  are displayed. • Off : <ul style="list-style-type: none"> - The boiler is shut down and frost protection is active. - The symbol  is displayed.
Room temperature CH1	Room temperature set point in comfort mode.	
Hot water heating	Setting domestic hot water production.	<ul style="list-style-type: none"> • On : Enables domestic hot water production. • Off : <ul style="list-style-type: none"> - Disables domestic hot water production. - The symbol  disappears from the display. • Eco : Not used.
Hot water temp setpoint	Domestic hot water temperature set point.	

9.1.2 Information menu

Tab.32 Menu Information

Information	Description	Value
Room temperature	Is displayed if the control system unit is configured as a room temperature appliance	
Room temperature min		
Room temperature max		
Boiler temperature	Boiler flow temperature	°C
Outside temp	Outside temperature	°C

Information	Description	Value
Outside temp min	Minimum outside temperature value memorised  Note The outside sensor must be connected.	°C
Outside temp max	Maximum outside temperature value memorised  Note The outside sensor must be connected.	°C
Hot water temp 1	Domestic hot water temperature  Note The value displayed comes from the sensor on the boiler's domestic hot water circuit.	°C
Collector temp 1	Instantaneous temperature of the solar panel sensor (when associated to a solar system)	°C
State central heating CH1	Operating mode of heating circuit 1	
State central heating CH2	Operating mode of heating circuit 2	
State central heating CH3	Operating mode of heating circuit 3	
State hot water	Domestic hot water circuit operating mode	
State boiler	Boiler operating mode	
State solar	Indicates solar running (when associated to a solar system)	-
Telephone customer service	Telephone number of the After Sales Service	No.

9.1.3 List of user parameters

Tab.33 Menu **Set time and date**

Parameter number	Parameter	Description
1	Hours / minutes	Setting the time
2	Day / month	Setting the day and the month
3	Year	Setting the year

Tab.34 Menu **Operator section**

Parameter number	Parameter	Description	Factory setting
20	Change Language	Setting the interface language	English
27	Programming lock	Setting the programming lock • Off : the parameters can be displayed and modified • On : the parameters can be displayed but cannot be modified	Off

Tab.35 Menu **Time program**

Parameter number			Parameter	Description
Heating circuit 1	Heating circuit 2	Heating circuit 3		
500	520	540	Select days	Selecting the days or group of days for the timer program.
514	534	554	Mon-Sun	Selecting a default timer program.
501	521	541	1st Time ON	Start of timer period 1.
502	522	542	1st Time OFF	End of timer period 1.
503	523	543	2nd Time ON	Start of timer period 2.
504	524	544	2nd Time OFF	End of timer period 2.

Parameter number			Parameter	Description
Heating circuit 1	Heating circuit 2	Heating circuit 3		
505	525	545	3rd Time ON	Start of timer period 3.
506	526	546	3rd Time OFF	End of timer period 3.
516	536	556	Default values	Reset the timer programming parameters (Yes / No)

Tab.36 Menu Time hot water

Parameter number	Parameter	Description
560	Select days	Selecting the days or group of days for the timer program.
574	Mon-Sun	Selecting a default timer program.
561	1st Time ON	Start of timer period 1.
562	1st Time OFF	End of timer period 1.
563	2nd Time ON	Start of timer period 2.
564	2nd Time OFF	End of timer period 2.
565	3rd Time ON	Start of timer period 3.
566	3rd Time OFF	End of timer period 3.
576	Default values	Reset the timer programming parameters (Yes / No).

Tab.37 Menu Holiday Settings

Parameter number			Parameter	Description	Factory setting
Heating circuit 1	Heating circuit 2	Heating circuit 3			
641	651	661	Select	Selecting the holiday period	Period 1
642	652	662	Start	Selecting the day and month of the start of the current holiday period.	
643	653	663	End	Selecting the day and month of the end of the current holiday period.	
648	658	668	Operating level	Boiler operating mode during the holiday period. • Off • Reduced	Off

Tab.38 Menu Temps / mode CH1 – Temps / mode CH2 – Temps / mode CH3

Parameter number			Parameter	Description	Factory setting
Heating circuit 1	Heating circuit 2	Heating circuit 3			
700	1000	1300	Operating mode	The control unit is installed on the boiler: • Off : heating is deactivated. • Timed : heating is dependent on the timer program. • Reduced : heating is in permanent reduced mode. • On : heating is in permanent comfort mode. The control unit is installed as a room temperature control system: • Off : the boiler starts up when the room temperature falls below the frost protection set point. • Timed : heating is dependent on the timer program. • Reduced : the room temperature set point is the reduced set point (parameters 712, 1010, 1310) • On : the room temperature set point is the comfort set point (parameters 710, 1010, 1310)	On

Parameter number			Parameter	Description	Factory setting
Heating circuit 1	Heating circuit 2	Heating circuit 3			
710	1010	1310	Comfort setpoint		20°C
712	1012	1310	Reduced temp setpoint		16°C

9.1.4 List of installer parameters

Tab.39 Menu Operator section

Parameter number	Parameter	Description	Factory setting
24	Lighting	<ul style="list-style-type: none"> • Off • Temporarily • Permanently 	Temporarily
29	Units	<ul style="list-style-type: none"> • °C, bar • °F, PSI 	°C, bar
40	Used as	<ul style="list-style-type: none"> • Operator unit 1 : The control system unit is installed on the boiler. • Room unit 1 : The control system unit is configured as a room temperature unit for heating circuit 1. • Room unit 2 : The control system unit is configured as a room temperature unit for heating circuit 2. • Room unit 3 : The control system unit is configured as a room temperature unit for heating circuit 3. 	Operator unit 1
42	Assignment device 1	<p>As Room Temperature Unit 1, the action of the control system unit can be assigned to CH1 or to two heating circuits:</p> <ul style="list-style-type: none"> • Temps / mode CH1 • Central heating 1 and 2 • Central Heating 1 and 3 • All central heatings 	All central heatings
43	Action operation	<ul style="list-style-type: none"> • Locally : The room temperature unit controls only the respective heating circuit. • Centrally : Only room temperature unit 1 can be centralised. It also controls the domestic hot water and standby mode. 	Centrally
54	Readjustment room sensor	-3°C to +3°C	0°C
70	Software version		

Tab.40 Temps / mode CH1 - Temps / mode CH2 menus - Temps / mode CH3

Parameter number			Parameter	Description	Unit	Factory setting
Heating circuit 1	Heating circuit 2	Heating circuit 3				
714	1014	1314	Frost protection setpoint		°C	6
720	1020	1320	Heating curve slope	Heating curve gradient: The regulator calculates the flow temperature set point which is used for the control system, according to outside weather conditions.	–	<ul style="list-style-type: none"> • Heating circuit 1: 1.5 • Heating circuit 2: 1.5 • Heating circuit 3: 1.5

Parameter number			Parameter	Description	Unit	Factory setting
Heating circuit 1	Heating circuit 2	Heating circuit 3				
730	1030	1330	Summer/winter heating limit	Limit temperature for switching between Heating/Protection mode. Triggers or shuts down the heating in the course of the year according to variations in outside temperature. This switch is made automatically in Automatic Mode.		20
732	1032	1332	24-hour heating limit	The heating is shut down when the outside temperature is equal to the room temperature + parameter 732 (deactivated in Comfort mode).	°C	0
740	1040	1340	Flow temp setpoint min	The flow set point calculated is limited by the set value.	°C	25
741	1041	1341	Flow temp setpoint max	The flow set point calculated is limited by the set value.	°C	80
742	1042	1342	Flow temp setpoint room stat	The set flow value is applied in room temperature thermostat mode. '---' the boiler is running in modulation mode.	°C	80
750	1050	1350	Room influence	<ul style="list-style-type: none"> Influence of the room temperature and the outside temperature on calculating the flow temperature: ---%: Simple regulation in accordance with outside weather conditions: 1...99%: Regulation in accordance with outside weather conditions with room temperature influence. 100%: Regulation in accordance with the room temperature only. 	%	50
760	1060	1360	Room temp limitation	Cuts the circulating pump if the room temperature exceeds the current set point + parameter 760, 1060, 1360.	°C	0.5
809	1109	1409	Continuous pump operation	<ul style="list-style-type: none"> No : The heating circuit / boiler pump may be shut down during an accelerated decline in temperature or when the room temperature set point is reached. Yes : The heating circuit / boiler pump also continues to run during the accelerated decline in temperature and when the room temperature set point is reached. 	-	no
834	1134	1434	Actuator running time	Setting the stroke of the servomotor on the mixing valve used	seconds	30
850	1150	1450	Floor curing function	Controlled screed-drying function: <ul style="list-style-type: none"> Off : The function is inoperative. Curing/functional heating : Active for 7 days, 3 days at 25°C and 4 days at 55°C. Curing heating : Active for 18 days, 6 days from 25°C to 55°C increasing by 5°C a day, 6 days at 55°C, 6 days from 55°C to 25°C diminishing by 5°C a day. Functional/curing heating : "Functional Heating" cycle first, and then "Ready for Occupation". Manually : Regulation is based on the "Manual Control Drying" set point. 	S	Off
851	1151	1451	Floor curing setp manually	The flow temperature set point of the "Manual" controlled drying function can be set separately for each heating circuit.	°C	25
855	1155	1455	Floor curing setp current	Displays the current day of the controlled screed-drying function. With '---' the function is deactivated.	-	'---'

Parameter number			Parameter	Description	Unit	Factory setting
Heating circuit 1	Heating circuit 2	Heating circuit 3				
856	1156	1456	Days complete.current	Displays the current flow temperature set point of the controlled screed-drying function. With '---' the function is deactivated.	-	'---'

Tab.41 Menu Temps / mode hot water

Parameter number	Parameter	Description	Factory setting
1600	Operating mode	<ul style="list-style-type: none"> • Off: Permanent running at the frost-protection set point. • On : Domestic hot water loading is done automatically at the nominal set point. • Eco : The temperature maintenance function is deactivated. 	On
1610	Hot water temp setpoint	DHW set point during release times	60°C
1612	Reduced temp setpoint	Reduced set point outside release times	35°C
1620	Release	Start-up enabled: <ul style="list-style-type: none"> • Time hot water : This setting provides domestic hot water production with a dedicated timer program. • Time setting central heating : The release of domestic hot water is done with the same timer program as the heating circuits. • 24h/day : Default setting for instantaneous boilers. 	Time hot water
1640	Legionella function	<ul style="list-style-type: none"> • Off • Periodically • Fixed weekday 	Off
1641	Legionella funct periodically	Determines after how many days the anti-legionella function must be reactivated.	7
1642	Legionella funct weekday	Determines on which day the anti-legionella function must be activated.	Monday
1644	Legionella funct time	Determines the start-up time of the anti-legionella function (Hours / Minutes).	--/--
1660	Circulating pump release	The circulating pump is tripped during the release time: <ul style="list-style-type: none"> • Time central heating CH3 • Hot water release • Time hot water • Time auxiliary 	Hot water release
1663	Circulation setpoint	The regulator monitors the temperature measured while the anti-legionella function is running.	45°C
1680	Optg mode changeover	In cases of external switching via the Hx inputs, the regime to which the switch must be made must first be defined. <ul style="list-style-type: none"> • None • Off 	None

Tab.42 Menu Boiler Settings

Parameter number	Parameter	Description	Unit	Factory setting
2214	Setpoint manual control	In manual mode, the flow temperature set point can be set to a fixed value.	°C	80°C
2441	Fan output heating max	Maximum fan speed in heating mode.	rpm	depending on the model

Tab.43 Solar menu (with additional extension module)

Parameter number	Parameter	Description	Unit	Factory setting
3810	Temp diff on	Min. ΔT between the solar collector sensor and the solar domestic hot water tank for running the solar pump.	°C	8
3811	Temp diff off	Max. ΔT between the solar collector sensor and the solar domestic hot water tank for shutting down the solar pump.	°C	4
3830	Collector start function	To measure the temperature on the solar collector correctly (pipes empty) (--- = deactivated)	min	30
3831	Min run time collector pump	Minimum running of the collector pump.	Seconds	30
3850	Collector overtemp prot	If there is a danger of overheating in the collector, tank loading continues to eliminate any excess heat.	°C	120















Tab.44 Menu Configuration







Parameter number	Parameter	Description	Factory setting
5710	Temps / mode CH1	Activation of heating circuit 1: • Off • On	On
5715	Temps / mode CH2	Activation of heating circuit 2: • Off • On	Off
5721	Temps / mode CH3	Activation of heating circuit 3: • Off • On	Off
5730	Hot water sensor	Selection of the domestic hot water sensor: • Hot water sensor B3 : Domestic hot water sensor for tank • Thermostat : The sensor used for domestic hot water is a thermostat	Hot water sensor B3
5731	HW controlling element	Type of actuator for controlling the domestic hot water requirement: • No charging request : No function • Charging pump : Domestic hot water loading is done with a pump. • Diverting valve : Domestic hot water loading is done with a bypass valve.	Diverting valve

Parameter number	Parameter	Description	Factory setting
5890	Relay output QX1	<ul style="list-style-type: none"> • None • Circulating pump Q4 : Domestic hot water circulating pump. • El imm heater HW K6 • Collector pump Q5 : Circulating pump for the solar collector circuit. • Cons circuit pump VK1 Q15 : The VK1 consumer circuit pump can be used for an additional consumer boiler. • Boiler pump Q1 : The pump connected is used for circulating the boiler water. • Bypass pump Q12 • Alarm output K10 : Presence of an error signalled by relay. Closure of the contact is on a time delay of 2 min. • 2nd pump speed CH1 Q21 • 2nd pump speed CH2 Q22 • 2nd pump speed CH3 Q23 • heating pump CH3 Q20 : The heating circuit with CH3 pump is activated (3WV Zone). • Cons circuit pump VK2 Q18 • System pump Q14 : The pump connected is used as the mains pump. • Heat gen shutoff valve Y4 • Solid fuel boiler pump Q10 : Integration of a solid fuel boiler: Circulating pump in the boiler circuit. • Time setting 5 K13 : The relay is controlled according to the settings on timer program 5. • Buffer return valve Y15 • Solar pump ext exch K9 • Solar ctrl elem buffer K8 • Solar ctrl elem swi pool K18 : Contact for heating the swimming pool with solar energy (if using several heat exchangers). • Cons circuit pump VK2 Q18 • Cascade pump Q25 : Boiler pump common to all boilers in a cascade. • St tank transfer pump Q11 • Hot water mixing pump Q35 • HW intern circ pump Q33 • Heat request K27 • Refrigeration request K28 : Cooling requirement for cooling circuit 1. • heating pump CH1 Q2 : The heating circuit with CH1 pump is activated. • heating pump CH2 Q6 : The heating circuit with CH2 pump is activated. • Hot water ctrl elem Q3 : Pump / distribution valve for hot water tank. • Instant WH ctrl elem Q34 : Pump / distribution valve for boiler producing instantaneous hot water. • Water refill K34 : Solenoid filling valve command. • 2nd boiler pump speed Q27 : Boiler pump 2nd speed. • Status output K35 • Status information K36 • Flue gas damper K37 • Fan shutdown K38 : Fan shut-down function for cutting the power to the fan if it is not used. 	heating pump CH1 Q2

Parameter number	Parameter	Description	Factory setting
5931	Sensor input BX2	<ul style="list-style-type: none"> • None : No function on the sensor input. • Hot water sensor B31 : Sensor in the bottom section of the domestic hot water tank. • Collector sensor B6 : Solar collector sensor. • HW circulation sensor B39 : Circulation / DHW preparation sensor. • Buffer sensor B4 : Sensor in the top section of the storage tank. • Buffer sensor B41 : Sensor in the bottom section of the storage tank. • Flue gas temp sensor B8 : Flue gas sensor • Common flow sensor B10 : Common flow sensor (cascade). • Solid fuel boiler sensor B22 : Sensor for solid fuel boiler. • HW charging sensor B36 • Buffer sensor B42 : Third sensor (in the middle) of the storage tank. • Common return sensor B73 • Cascade return sensor B70 : Cascade return sensor. • Swimming pool sensor B13 : Swimming pool sensor. • Solar flow sensor B63 : Solar flow sensor for measuring efficiency. • Solar return sensor B64 : Solar return sensor for measuring efficiency. • Primary exch sensor B26 	None
5932	Sensor input BX3	 See Sensor input BX2	None
5970	Function input H4	<ul style="list-style-type: none"> • None : Default setting for boilers with domestic hot water tank. • Flow measurement Hz : Default setting for instantaneous boilers. • Error/alarm message 	None
5971	Contact type H4	<ul style="list-style-type: none"> • NC • NO 	Error/alarm message
5973	Frequency value 1 H4	Definition of the parameters for collector specifications	15
5974	Function value 1 H4	Definition of the parameters for collector specifications	20
5975	Frequency value 2 H4	Definition of the parameters for collector specifications	162
5976	Function value 2 H4	Definition of the parameters for collector specifications	120

Parameter number	Parameter	Description	Factory setting
5977	Function input H5	<ul style="list-style-type: none"> • None • Optg mode change CHs+HW : Heating and domestic hot water circuit changeover mode. • Optg mode changeover HW : Domestic hot water circuit changeover mode. • Optg mode changeover CHs : The regimes of the heating circuits are switched to parameter mode on line 900-1200-1500. • Optg mode changeover CH1: The regimes of the heating circuits are switched to parameter mode on line 900-1200-1500. • Optg mode changeover CH2: The regimes of the heating circuits are switched to parameter mode on line 900-1200-1500. • Optg mode changeover CH3: The regimes of the heating circuits are switched to parameter mode on line 900-1200-1500. • Heat generation lock : The generator is locked. All heating circuit and domestic hot water temperature requirements are ignored. (boiler frost protection active) • Error/alarm message : The input causes an error message on the regulator • Consumer request VK1 : The input causes an error message on the regulator • Consumer request VK2 : The input causes an error message on the regulator • Release swimpool source htg : Swimming pool requirement • Excess heat discharge : Enables an external generator to force the switches (heating circuit, DHW, Hx pump) to dissipate any heat surplus. • Release swi pool solar : This function enables the release of solar swimming pool heating by an external resource. • Operating level HW : The temperature level can be adjusted by a contact (external timer program) rather than by the internal timer program. • Operating level CH1 : The temperature level can be adjusted by a contact (external timer program) rather than by the internal timer program. • Operating level CH2 : The temperature level can be adjusted by a contact (external timer program) rather than by the internal timer program. • Operating level CH3 : The temperature level can be adjusted by a contact (external timer program) rather than by the internal timer program. • Room thermostat CH1 : This input is used to generate a room temperature thermostat demand for heating circuit 1. • Room thermostat CH2: This input is used to generate a room temperature thermostat demand for heating circuit 2. • Room thermostat CH3: This input is used to generate a room temperature thermostat demand for heating circuit 3. • Hot water flow switch : Connection of the flow rate controller on the instantaneous water heater. • Hot water thermostat : Connection of the domestic hot water tank thermostat. • Pulse count : Impulse counter. • Checkb sign flue gas damper : Feedback on flue gas valve position. • Boiler flow switch : Start-up authorisation by flow rate controller. • Boiler pressure switch : Start-up authorisation by pressure switch. 	Room thermostat CH1
5978	Contact type H5	<ul style="list-style-type: none"> • NC • NO 	NO

Parameter number	Parameter	Description	Factory setting
6020	Function extension module 1	<ul style="list-style-type: none"> • None • Multifunctional : The functions that can be assigned to the inputs/ outputs. • Temps / mode CH1 : Settings corresponding to the operator chapter on "Heating Circuit 1". • Temps / mode CH2: Settings corresponding to the operator chapter on "Heating Circuit 2". • Temps / mode CH3 : Settings corresponding to the operator chapter on "Heating Circuit 3". • Return temp controller : Not used • Solar HW : Settings corresponding to the operator chapter on "Thermal Solar". • Primary contr/system pump : Not used 	Without
6021	Function extension module 2	 See Function extension module 1	Without
6022	Function extension module 3	 See Function extension module 1	None
6024	Funct input EX21 module 1	<ul style="list-style-type: none"> • None • Limit thermostat CH 	None
6026	Funct input EX21 module 2	 See Funct input EX21 module 1	without
6028	Funct input EX21 module 3	 See Funct input EX21 module 1	without
6030	Relay output QX21 module 1	 See QX1 relay outlet	without
6031	Relay output QX22 module 1	 See QX1 relay outlet	without
6032	Relay output QX23 module 1	 See QX1 relay outlet	without
6033	Relay output QX21 module 2	 See QX1 relay outlet	without
6034	Relay output QX22 module 2	 See QX1 relay outlet	without
6035	Relay output QX23 module 2	 See QX1 relay outlet	without
6036	Relay output QX21 module 3	 See QX1 relay outlet	without
6037	Relay output QX22 module 3	 See QX1 relay outlet	without
6038	Relay output QX23 module 3	 See QX1 relay outlet	without
6040	Sensor input BX21 module 1	 See BX2 sensor inlet	without
6041	Sensor input BX22 module 1	 See BX2 sensor inlet	without

Parameter number	Parameter	Description	Factory setting
6042	Sensor input BX21 module 2	 See BX2 sensor inlet	without
6043	Sensor input BX22 module 2	 See BX2 sensor inlet	without
6044	Sensor input BX21 module 3	 See BX2 sensor inlet	without
6045	Sensor input BX22 module 3	 See BX2 sensor inlet	without
6046	Function input H2 module 1	 See the H5 inlet function	without
6047	Contact type H2 module 1	<ul style="list-style-type: none"> • NC • NO 	NO
6049	Voltage value 1 H2 module 1	Definition of parameters for collector specifications	0
6050	Funct value 1 H2 module 1	Definition of parameters for collector specifications	0
6051	Voltage value 2 H2 module 1	Definition of parameters for collector specifications	0
6052	Funct value 2 H2 module 1	Definition of parameters for collector specifications	0
6054	Function input H2 module 2	 See the H5 inlet function	without
6055	Contact type H2 module 2	<ul style="list-style-type: none"> • NC • NO 	NO
6057	Voltage value 1 H2 module 2	Definition of parameters for collector specifications	0
6058	Funct value 1 H2 module 2	Definition of parameters for collector specifications	0
6059	Voltage value 2 H2 module 2	Definition of parameters for collector specifications	0
6060	Funct value 2 H2 module 2	Definition of parameters for collector specifications	0
6062	Function input H2 module 3	 See the H5 inlet function	without
6063	Contact type H2 module 3	<ul style="list-style-type: none"> • NC • NO 	NO
6065	Voltage value 1 H2 module 3	Definition of parameters for collector specifications	0
6066	Funct value 1 H2 module 3	Definition of parameters for collector specifications	0
6067	Voltage value 2 H2 module 3	Definition of parameters for collector specifications	0
6068	Funct value 2 H2 module 3	Definition of parameters for collector specifications	0
6097	Sensor type collector	Type of collector sensor: <ul style="list-style-type: none"> • NTC • Pt 1000 	NTC
6100	Readjustm outside sensor	The value of the outside temperature measurement can be offset by +/- 3°C.	0°C

Parameter number	Parameter	Description	Factory setting
6200	Save sensors	Records the sensors used in the appliance.	No
6212	Check no. heat source 1	Information on the manufacturer	
6213	Check no. heat source 2		
6215	Check no. storage tank		
6217	Check no. heating circuits		
6230	Info 1 OEM		
6231	Info 2 OEM		

Tab.45 Menu Error

Parameter number	Parameter	Description	Factory setting
6704	Display SW diagnostic code	Display of the software troubleshooting code: • No • Yes	Yes
6705	SW diagnostic code	Software troubleshooting code currently pending.	
6706	Burn ctrl phase lockout pos	Locking phase indicating the place where the error occurred.	
6710	Reset alarm relay	Alarm relay reset.	
6800	History 1	Last error that occurred.	
6805	SW diagnostic code 1	Last troubleshooting code that occurred.	
6806	Burner control phase 1	Last locking phase indicating the place where the error occurred.	
6810 – 6996	History 2 to History 20	Error history.	

Tab.46 Menu Service/special operation

Parameter number	Parameter	Description	Factory setting
7045	Time since maintenance	Resetting the boiler operating time after boiler servicing.	0 months
7130	Chimney sweep function	Chimney sweep function: • Off • On	Off
7131	Burner output	Burner output during the chimney sweep function: • Partial load • Full load • Max heating load	Full load
7140	Manual control	Manual control function: • Off • On	Off
7143	Controller stop function	Regulator shut-down function: • Off • On	Off
7145	Controller stop setpoint	Set point output during the regulator shut-down function: 0% to 100%	100%

Parameter number	Parameter	Description	Factory setting
7146	Deaeration function	Venting function: • Off • On	Off
7147	Type of venting	Venting cycle operating mode: • None • Heating circuit continuous • Heating circuit cycled • Hot water continuous • Hot water cycled	None
7170	Telephone customer service		
7231	Refill time current week	Value displayed	0 s
7232	Refill time to date	Value displayed	0 s
7233	Number of refills to date	Value displayed	0

Tab.47 Menu State

Parameter number	Parameter	Description
8000	State central heating CH1	
8001	State central heating CH2	
8002	State central heating CH3	
8003	State hot water	
8005	State boiler	
8007	State solar	
8008	State solid fuel boiler	
8009	State burner	
8010	State buffer	
8011	State swimming pool	

Tab.48 Menus Diagnostics heat generation

Parameter number	Parameter	Description
8310	• Boiler temperature • Control temp	Value displayed
8311	• Boiler setpoint • Control setpoint	
8313	Control sensor	
8314	Boiler return temp	
8315	Boiler return temp setpoint	
8316	Flue gas temp	
8321	Primary exchanger temp	
8323	Fan speed	
8326	Burner modulation	

Parameter number	Parameter	Description
8330	Hours run 1st stage	Value reset
8526	Solar Gain 24 Hour	
8527	Total Solar Gain	
8530	Hours run solar	
8531	Hours run collect overtemp	
8532	Hours run collector pump	

Tab.49 Menus **Burner control**

Parameter number	Parameter	Description
9512	Required speed ignition	Ignition speed set point adjustable on the operating interface.
9524	Required speed LF	Rotation speed set point at partial load adjustable on the operating interface.
9529	Required speed HF	Rotation speed set point at nominal load adjustable on the operating interface.
6624	Manual source lock	

9.2 Setting the parameters

9.2.1 Setting the date and time

Fig.69 Access to parameters

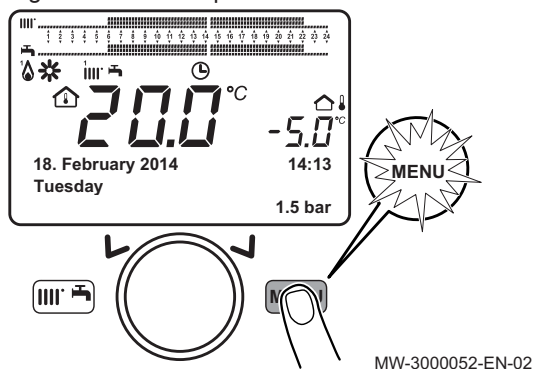

1. Press the **MENU** key to access the parameters.

Fig.70 Menu selection

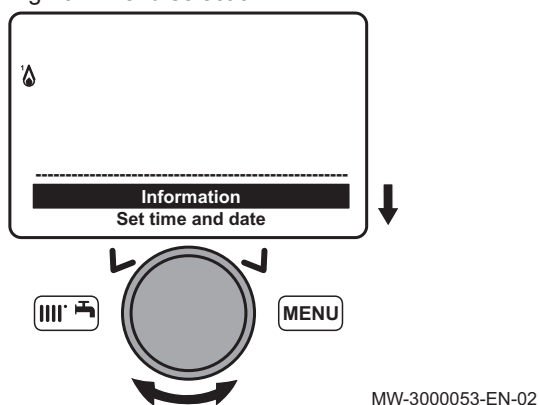

2. Select the **Set time and date** menu by turning the **⌚** button.

Fig.71 Time / Date parameter

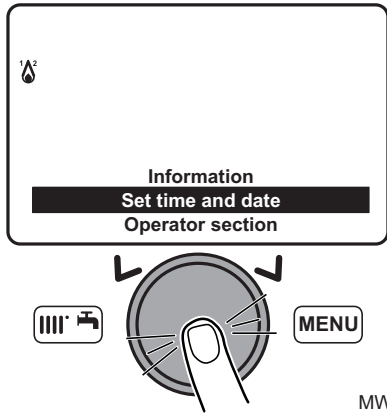

MW-3000054-EN-02

Fig.72 Modification possible prior to confirmation

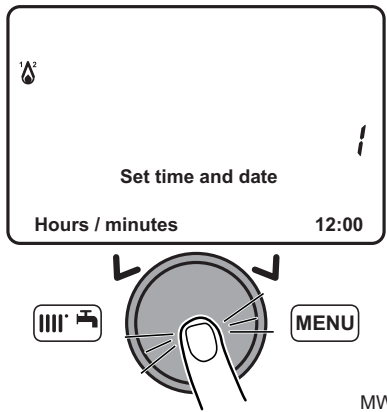

MW-3000055-EN-02

Fig.73 Selecting the Info Menu

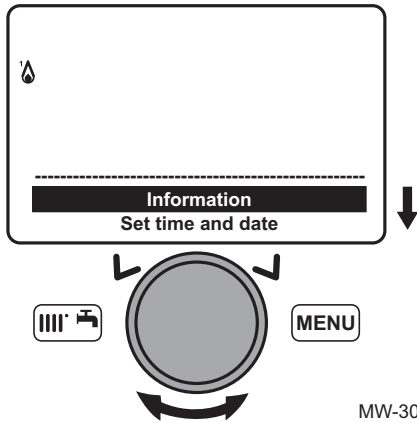

MW-3000056-EN-02

3. Confirm the menu selection by pressing the button . The parameter **Hours / minutes** appears.

4. Confirm the parameter selection by pressing the button. The parameter flashes, it can be modified.
5. Modify the parameter by turning the button.
6. Confirm the setting by pressing the button.
7. Set the other settings parameters if necessary.

Note
Press the key to return to the main display.

For more information, see
List of user parameters, page 62

9.2.2 Language Selection

1. Press the key to access the parameters.
2. Select the **Operator section** menu by turning the button.

Fig.74 Selecting the User Interface parameter

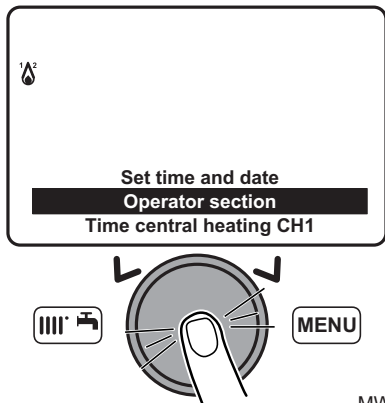

MW-3000057-EN-02

Fig.75 Selecting the Language parameter

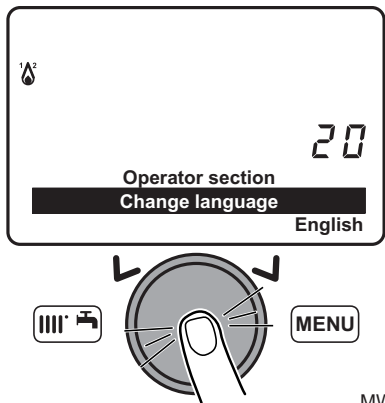

MW-3000058-EN-02

Fig.76 Selecting the Regime CH1 parameter

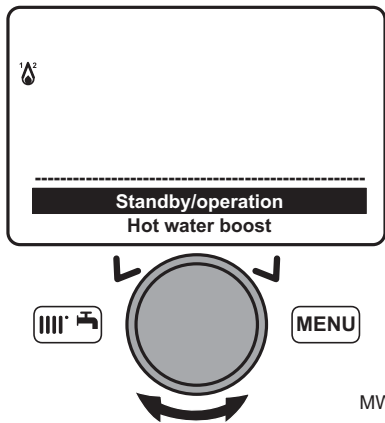

MW-3000059-EN-02

3. Confirm the menu selection by pressing the button . The **Change Language** parameter appears.

4. Confirm the menu selection by pressing the button . The language currently used flashes.
5. Modify the parameter by turning the button.
6. Confirm the setting by pressing the button.

Note
Press the key to return to the main display.

9.2.3 Changing the operating mode

1. Press the key to access the shortcuts menu.
2. Select the parameter **Central heating mode CH1** by turning the button.
3. Press the button to confirm.

Fig.77 Confirming the operating mode selected

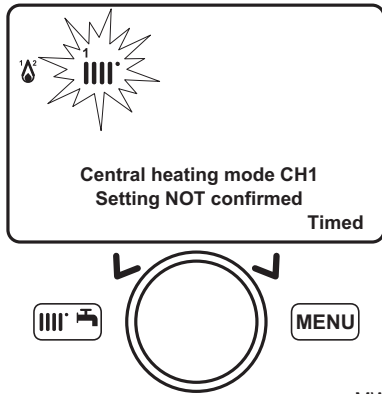

MW-3000060-EN-02

4. Select the appropriate operating mode.
5. Press the button to confirm.

Note
Press the key to return to the main display.

For more information, see
Shortcuts menu, page 61

Fig.78 Parameter selection 316:Hot water boost

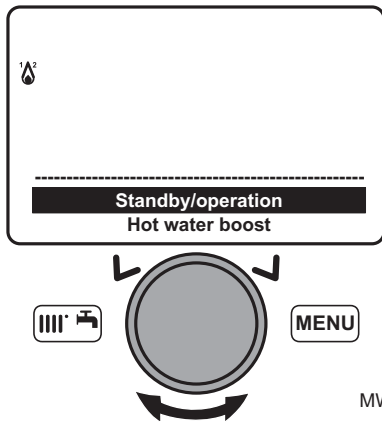

MW-3000061-EN-02

9.2.4 Forcing domestic hot water production

1. Press the key to access the shortcuts menu.
2. Select the parameter **316:Hot water boost** by turning the button.
3. Press the button to start forcing domestic hot water.

Note
Press the button a second time to stop forcing domestic hot water.

Note
Press the key to return to the main display.

For more information, see
Shortcuts menu, page 61

Fig.79 Selecting the parameter Room temperature CH1

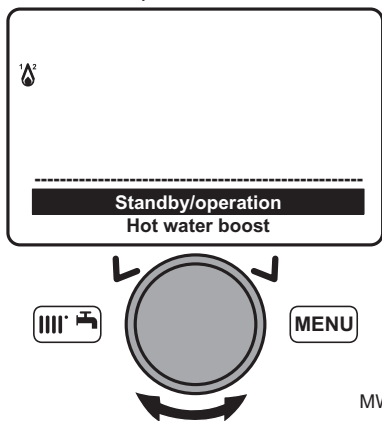

MW-3000062-EN-02

9.2.5 Setting the room temperature set point (Onmode)

1. Press the key to access the shortcuts menu.
2. Select the parameter **Room temperature CH1** by turning the button.
3. Press the button to confirm.

Fig.80 Modification of the temperature set point

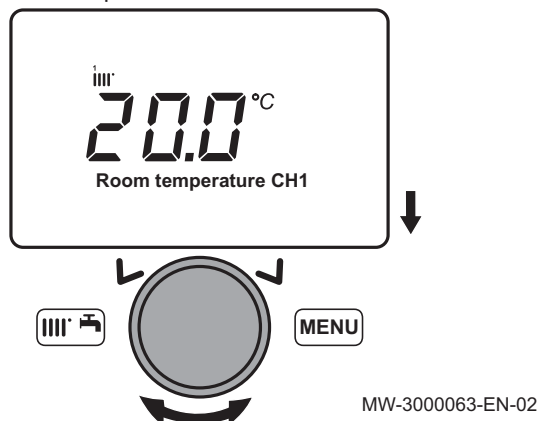

4. Turn the  button to modify the temperature set point.
5. Press the  button to confirm.

**Note**





Press the  key to return to the main display.

**For more information, see**

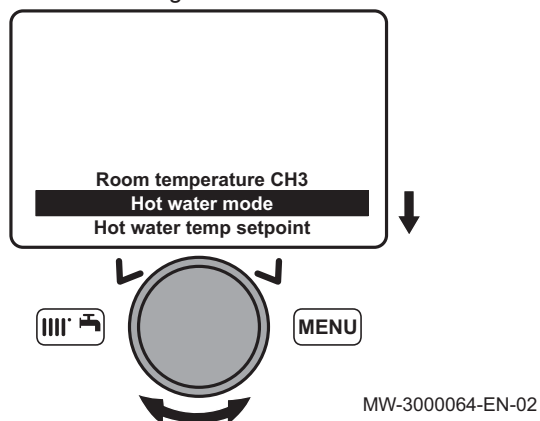
Shortcuts menu, page 61

Fig.81 Selecting the parameter Hot water heating



1. Press the  key to access the shortcuts menu.
2. Select the parameter **Hot water heating** by turning the  button.
3. Press the  button to confirm.
4. Select the appropriate operating mode.
5. Press the  button to confirm.

**Note**

Press the  key to return to the main display.

**For more information, see**

Shortcuts menu, page 61

Fig.82 Selecting the parameter Hot water temp setpoint

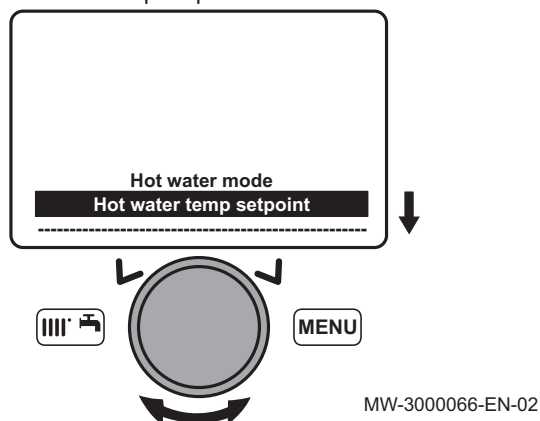





1. Press the  key to access the shortcuts menu.
2. Select the parameter **Hot water temp setpoint** by turning the  button.
3. Press the  button to confirm.

Fig.83 Modification of the temperature set point

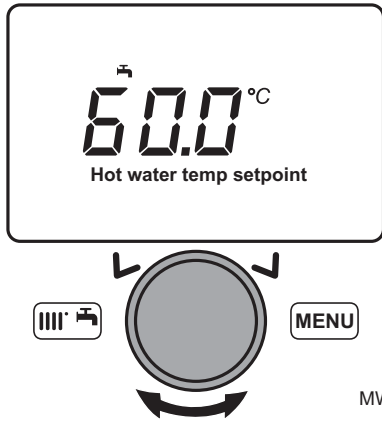

MW-3000067-EN-02

4. Turn the  button to modify the temperature set point.
5. Press the  button to confirm.



Note

Press the  key to return to the main display.



For more information, see
Shortcuts menu, page 61

Fig.84 Selecting the menu Temps / mode CH1

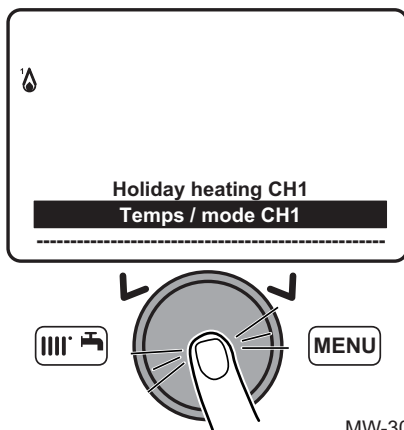

MW-3000068-EN-03



1. Press the  key to access the parameters.
2. Select the **Temps / mode CH1** menu by turning the  button.
3. Confirm the menu selection by pressing the button .
The parameter **Operating mode** appears.

Fig.85 Selecting the menu Reduced temp setpoint



MW-3000129-EN-02

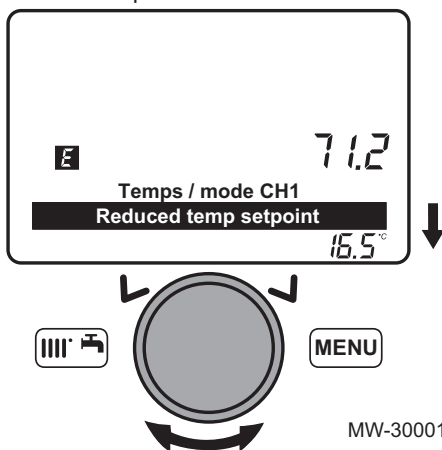

4. Select the **Reduced temp setpoint** menu by turning the  button.
5. Confirm the menu selection by pressing the button .
The room temperature set point (Reducedmode) flashes.

Fig.86 Modification of the temperature set point



6. Turn the button to modify the temperature set point.
7. Press the button to confirm.

Note
Press the key to return to the main display.

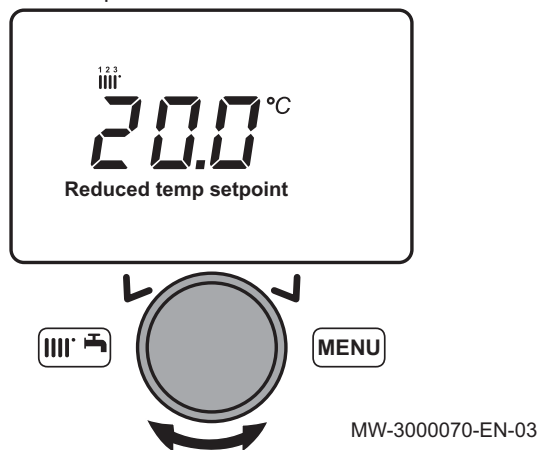
9.2.9 Programming a Holiday period

This series of functions is used to program the boiler's behaviour in holiday periods or during prolonged absences. The various parameters are used to program one of eight Holiday periods.

Note
When the function is activated, the symbol is displayed.

1. Press the key to access the parameters.
2. Select the **Holiday heating CH1** menu by turning the .

Fig.87 Menu selection Holiday heating CH1

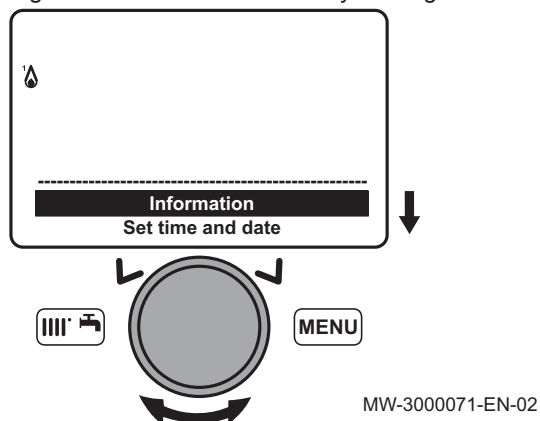
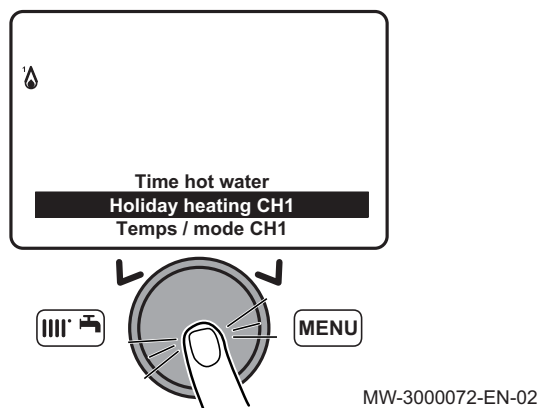

Fig.88 Confirming the menu Holiday heating CH1



3. Confirm the menu selection by pressing the button . The **Select** parameter appears.

Fig.99 Selecting the holiday period

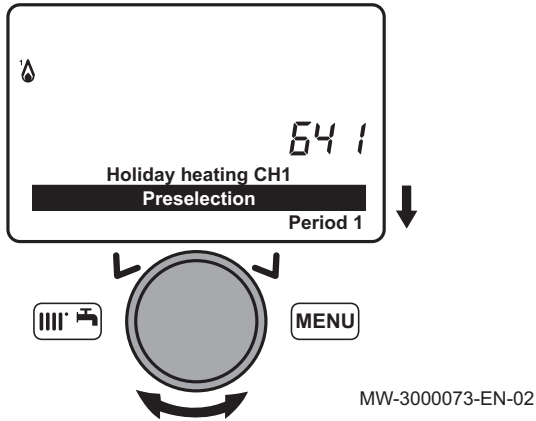

Fig.90 Confirming the holiday period selected

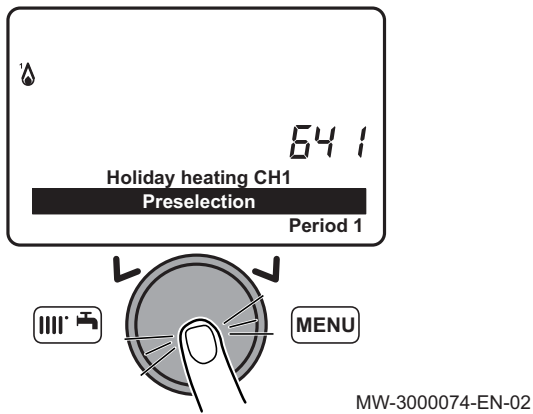

Fig.91 Confirming the period selected

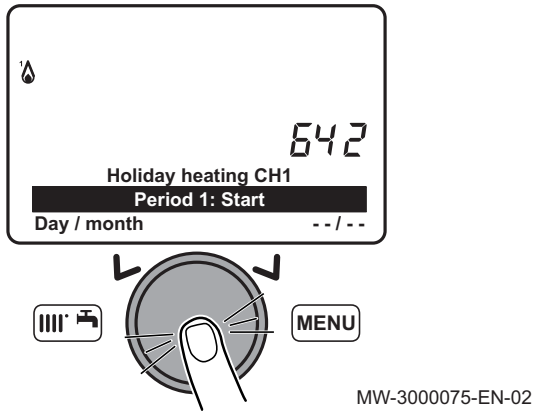
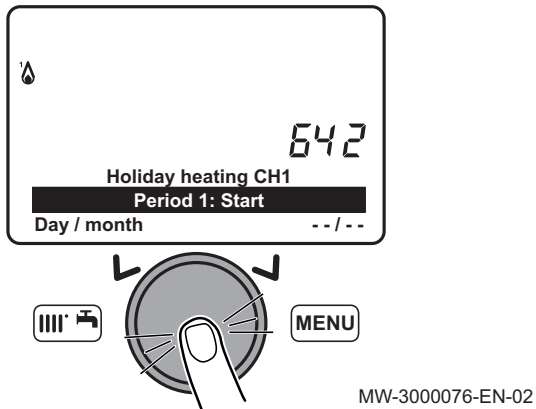







Fig.92 Confirming the start date of the holiday period



4. Select the Holiday period to be programmed by turning the  button.

5. Confirm by pressing the .

6. Select the **Start** parameter by turning the  button.
7. Confirm the menu selection by pressing the button .

8. Select and confirm the start date of the holiday period with the .

9. Confirm the menu selection by pressing the button .

Fig.93 Selecting the end date of the holiday period

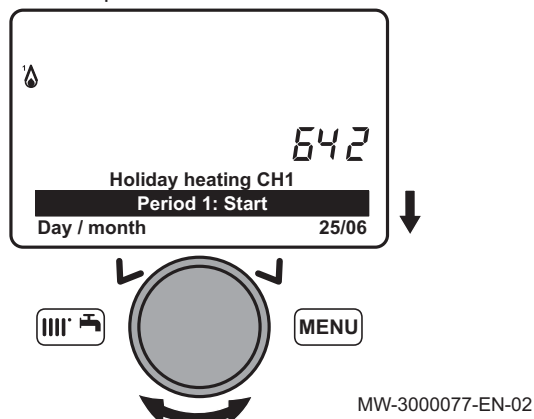

Fig.94 Confirming the end date of the holiday period

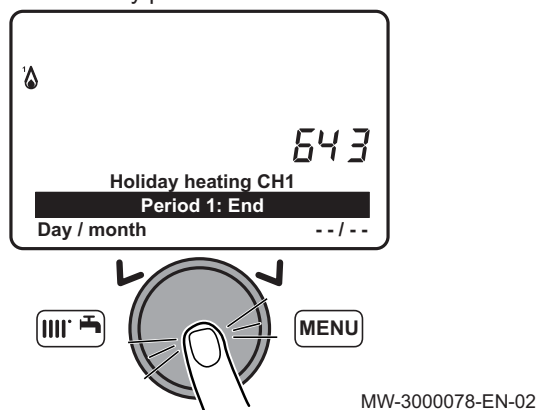

Fig.95 Selecting the parameter Operating level

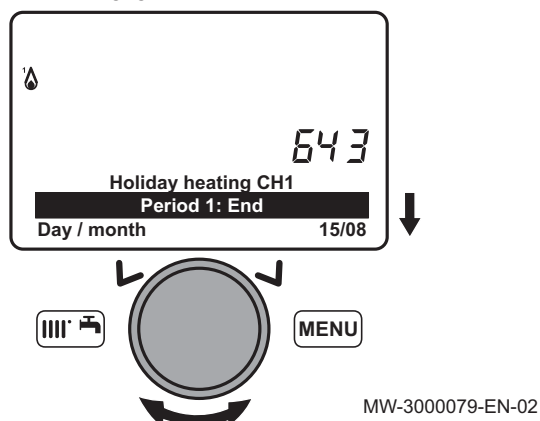
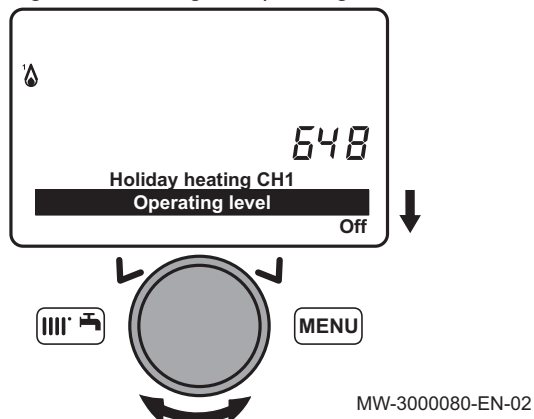

Fig.96 Selecting the operating mode



10. Select the **End** parameter by turning the button.

11. Select and confirm the end date of the holiday period with the .

12. Confirm the menu selection by pressing the button .

13. Select the **Operating level** parameter by turning the button.

14. Confirm the menu selection by pressing the button .

15. Select the boiler's operating mode during the holiday period by turning the button.

16. Confirm the menu selection by pressing the button .



For more information, see

Setting the room temperature set point (Onmode), page 78

Setting the room temperature set point (Reduced mode), page 80

Activating the Off, page 60

9.2.10 Using the boiler according to thermal output

Using the boiler according to thermal output makes it possible to calibrate the gas valve.



1. From the home screen, press the  and  keys simultaneously.

Fig.97 Home screen



MW-3000085-EN-02

Fig.98 Selecting parameter Controller stop function

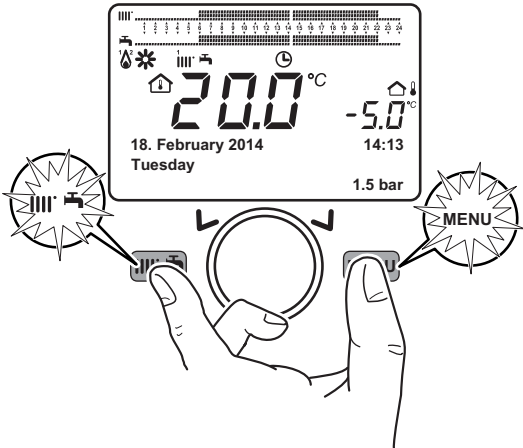
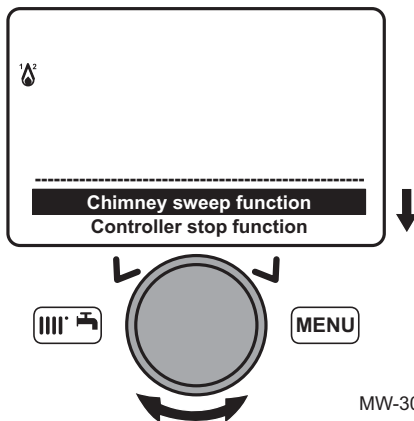

MW-3000086-EN-02

2. Select the parameter **Controller stop function** by turning the  button.

Fig.99 Confirming the parameter selected

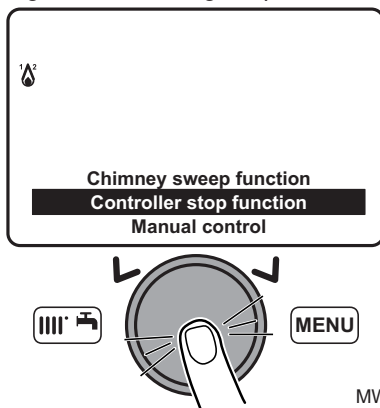

MW-3000087-EN-02

3. Press the  button to confirm.
The parameter **Controller stop function On** appears.

Fig. 100 Confirming the thermal output value



- Press the button to confirm.
304:Controller stop appears.

Fig. 101 Modifying the thermal output value

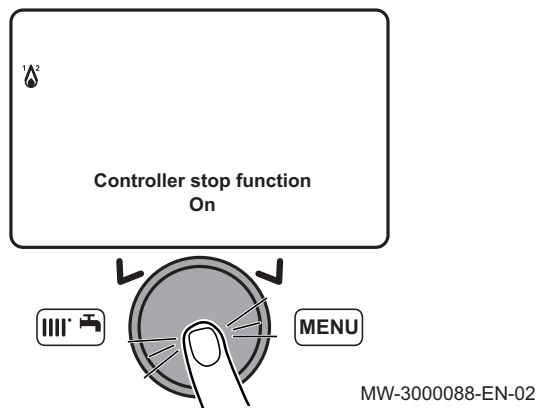
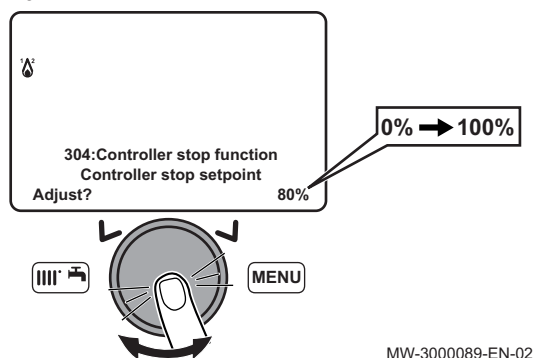

- Press the button to modify the thermal output value from 0 to 100% by turning the .
- Press the button to confirm the thermal output.

Note
Press the key to return to the main display and reactivate the control system.

For more information, see
Setting the air/gas ratio (maximum heat input), page 0
Setting the air/gas ratio (reduced heat input), page 0

9.2.11 Selecting a heating circuit

The control panel can manage up to three different heating circuits.

- From the home screen, turn the button to select one of the three heating circuits available.
- Press the button to confirm.
- Turn the button to temporarily modify the temperature set point on the selected heating circuit.
- Press the button to confirm.
The selected heating circuit is active.

9.2.12 Locking / Unlocking parameter modification

It is possible to lock all functions associated with the key to prevent unauthorised persons from modifying the parameters.

■ Locking parameter modification

- Press the key to access the user parameters menu.
- Select the **Operator unit** menu by turning the .
- Confirm the menu selection by pressing the button .

Fig. 102 Menu selection Operator unit

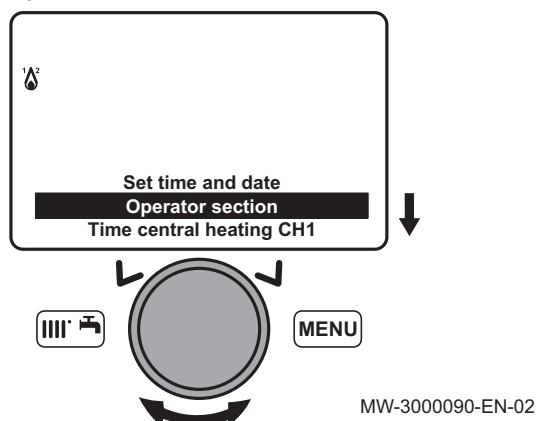
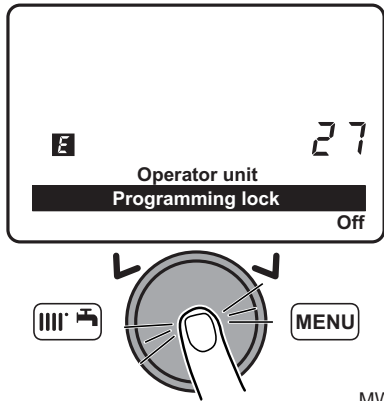

Fig. 103 Menu selection Programming lock



MW-3000091-EN-02

4. Select menu 27 **Programming lock** by turning the button.
5. Confirm the menu selection by pressing the button .

Fig. 104 Confirming the menu selection

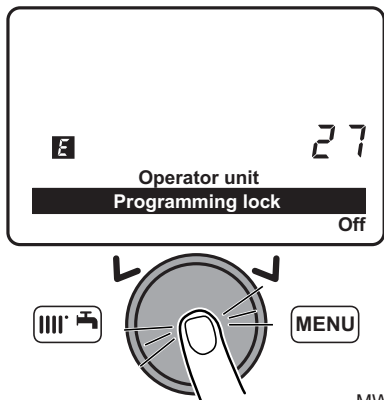

MW-3000092-EN-02

6. Select the setting **On** by turning the button.
7. Confirm the menu selection by pressing the button . The parameters can be displayed but cannot be modified.

Fig. 105 Unlocking

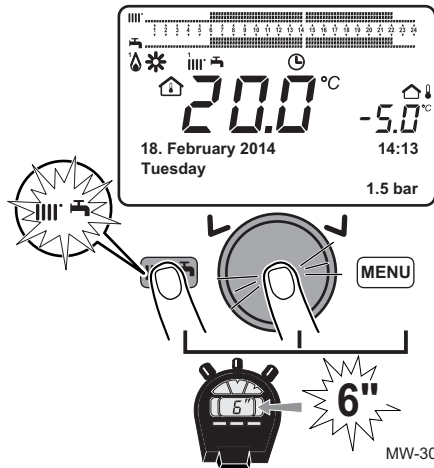

MW-3000093-EN-02

■ Unlocking parameter modification

It is necessary to proceed via a temporary unlocking phase to modify the **Programming lock** parameter, which is used to lock / unlock parameter modification.

1. Press the key to access the user parameters menu.
2. Press the key and the button simultaneously for around 6 seconds. **temporarily unlocked** is displayed.



Note

Unlocking is temporary and lasts 1 minute.

3. Press the key to access the user parameters menu.

Fig. 106 Confirming the menu Operator unit

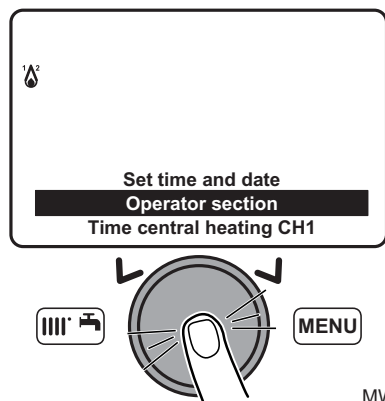

MW-3000094-EN-02

Fig. 107 Confirming the parameter On

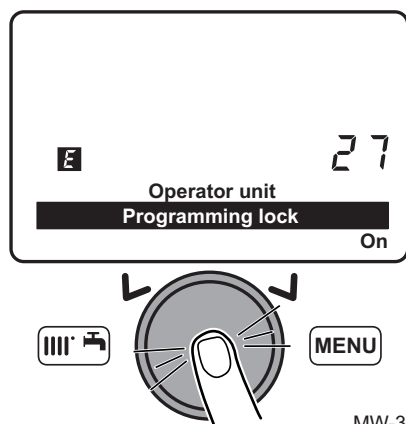



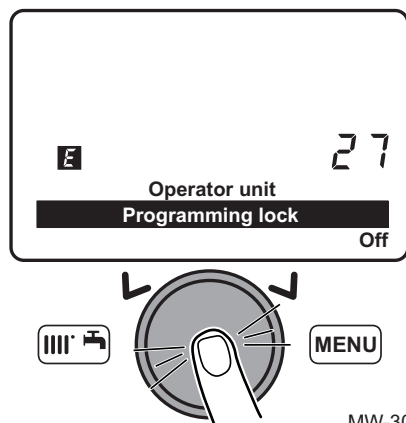

MW-3000096-EN-02



Fig. 108 Confirming the parameter Off



MW-3000095-EN-02

4. Select the **Operator unit** menu by turning the  button.
5. Confirm the menu selection by pressing the button .

6. Select menu 27 **Programming lock** by turning the .
7. Confirm the menu selection by pressing the button .

8. Select the setting On by turning the .
 9. Confirm the menu selection by pressing the button .
- The parameters can be modified.

9.2.13 Timer program



Note

Activate the operating mode **Timed**

The various timer programming functions are used to program start-up and automatic shut-down of the boiler during predefined time ranges. Timer programming is done for days of the week, from Monday to Sunday. Groups of days are predefined.

Tab.50 Weekly intervals

Values of the parameters **Select days** (500, 520, 540) for heating circuits 1, 2 and 3 and the parameters **Select days** (560) for domestic hot water.

Pre-setting selected	Days programmed
Mon-Sun	Monday - Tuesday - Wednesday - Thursday - Friday - Saturday - Sunday
Mon-Fri	Monday - Tuesday - Wednesday - Thursday - Friday
Sat-Sun	Saturday - Sunday
Mon	Monday
Tue	Tuesday
Wed	Wednesday
Thu	Thursday
Fri	Friday
Sat	Saturday
Sun	Sunday

Fig. 109 Example of a time range

- 1 Period of operation at the comfort temperature
- 2 Period of operation in reduced mode

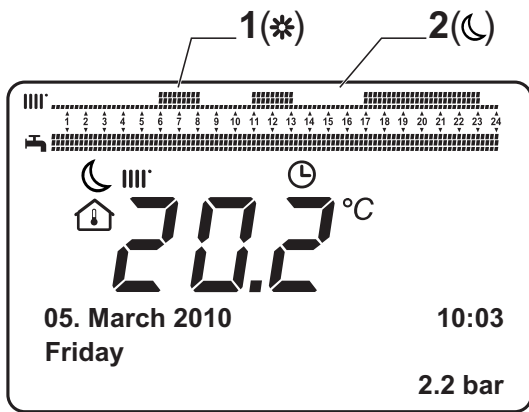

BM-0000025-GB-03

Tab.51 Daily time ranges

Values of the parameters **Select default timings?** (514, 534, 554) for heating circuits 1, 2 and 3 and the parameter **Select default timings?** (574) for domestic hot water.

Pre-setting selected	Hours programmed
Time setting 1	6:00 to 23:00
Time setting 2	06:00...08:00 – 17:00...23:00
Time setting 3	06:00...08:00 – 11:00...13:00 – 17:00...23:00



For more information, see Changing the operating mode, page 77

■ Default time ranges

Tab.52 Time ranges according to the groups of days selected

Program line 514 (heating), 574 (domestic hot water)

Groups of days	Pre-set programs		
	On 1 - Off 1	On 2 - Off 2	On 3 - Off 3
Mon-Sun	06:00 - 08:00	11:00 - 13:00	17:00 - 23:00
Mon-Fri	06:00 - 08:00		17:00 - 23:00
Sat-Sun	06:00 - 23:00		

Tab.53 Time ranges according to the days selected

Program line 501, 502, 503, 504, 505, 506 (heating) - 561, 562, 563, 564, 565, 566 (domestic hot water)

Single days	Pre-set programs		
	On 1 - Off 1	On 2 - Off 2	On 3 - Off 3
Monday-Tuesday- Wednesday-Thurs- day-Friday-Satur- day-Sunday	06:00 - 08:00	11:00 - 13:00	17:00 - 23:00



For more information, see
Changing the operating mode, page 77

■ Selecting a Timer Program

1. Select a heating circuit.
2. Press the key to access the parameters.
3. Select the **Time central heating CH1** menu by turning the button.

Fig. 110 Selecting the menu Time central heating CH1

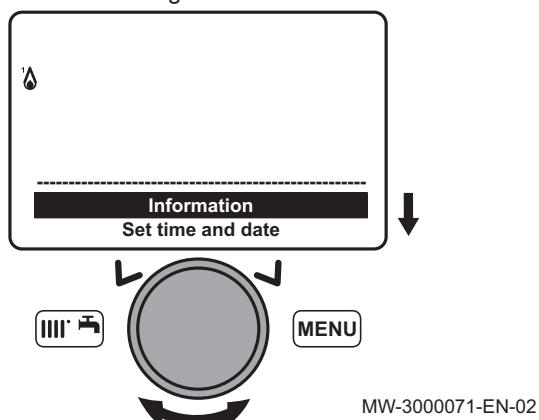

Note

- For heating circuits 2 and 3, select the parameters **Time central heating CH2** or **Time setting 3/CHP**.
 - For the domestic hot water circuit, select the parameter **Time hot water**.
4. Confirm the menu selection by pressing the button. The parameter **Select days** (500, 520, 540 or 560) appears.

Fig. 111 Selecting the parameter Select days

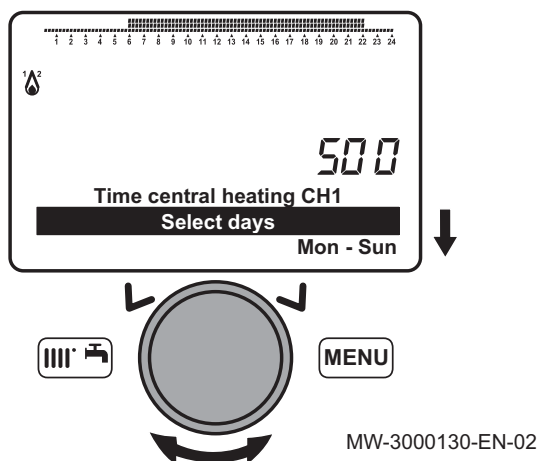

5. Confirm the parameter selection by pressing the button. The current selection flashes.
6. Select a weekly interval by turning the button.
7. Confirm the weekly interval selection by pressing the button.

Fig. 112 Selecting the parameter **Select default timings?**

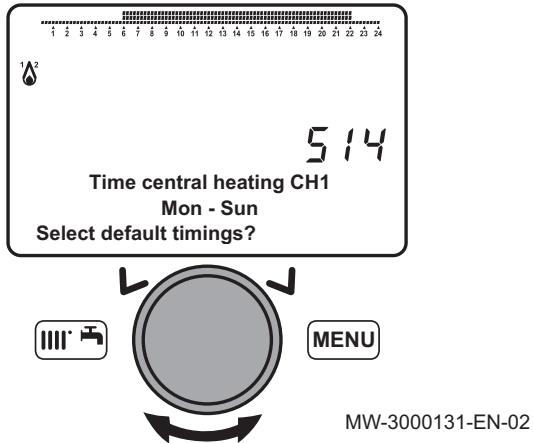

Fig. 113 Selecting the desired time range

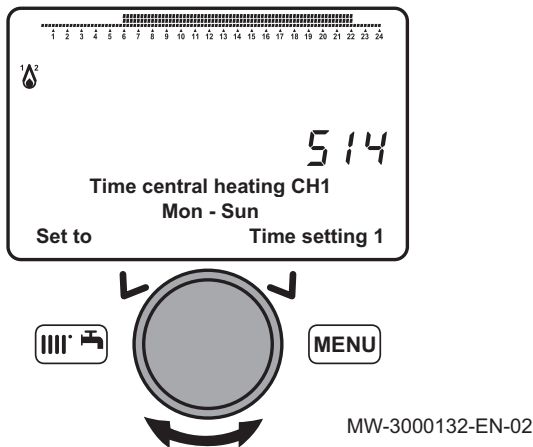
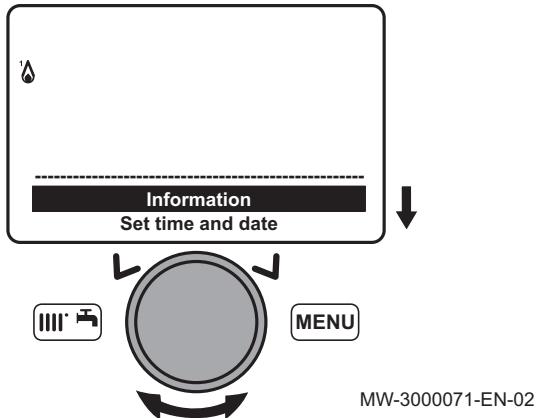

Fig. 114 Selecting the menu **Time central heating CH1**



8. Select the parameter **Select default timings?** (514, 534, 554 or 574) by turning the button.

9. Confirm the parameter selection by pressing the .
10. Select the desired time range by turning the button.
11. Confirm the time range selection by pressing the .

Note
Press the key to return to the main screen.

For more information, see
Changing the operating mode, page 77
Copying a time range, page 92

■ **Customising the time ranges**

1. Select a heating circuit.
2. Press the key to access the parameters.
3. Select the **Time central heating CH1** menu by turning the button.

Note

- For heating circuits 2 and 3, select the parameters **Time central heating CH2** or **Time setting 3/CHP**.
- For the domestic hot water circuit, select the parameter **Time hot water**.

4. Confirm the menu selection by pressing the button .
- The parameter **Select days** (500, 520, 540 or 560) appears.

Fig. 115 Selecting the parameter Select days

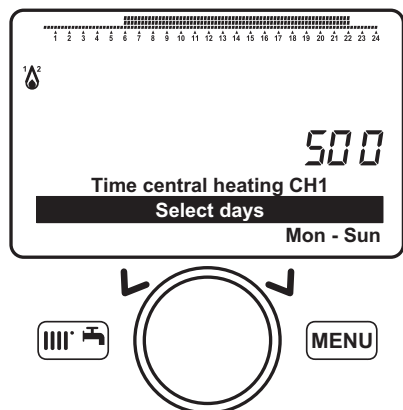

MW-3000133-EN-02



5. Confirm the menu selection by pressing the button .
- The current selection flashes.
6. Select a weekly interval.
7. Confirm the menu selection by pressing the button .

Fig. 116 Selecting the time range start time of parameter 1st Time ON



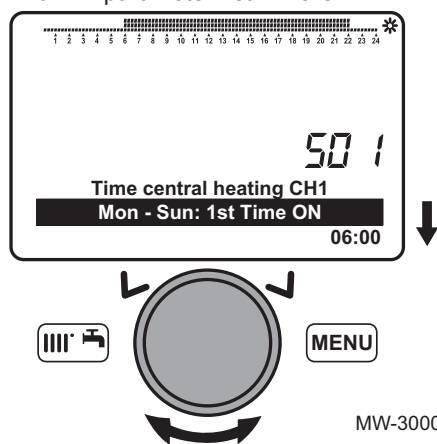

MW-3000134-EN-02

8. Select the parameter **1st Time ON** (501, 521, 541 or 561) by turning the .

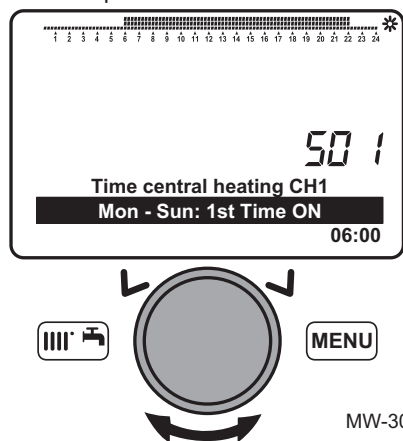
Fig. 117 Selecting the time range start time of parameter 1st Time ON



MW-3000135-EN-02

9. Confirm the menu selection by pressing the button .
- The beginning of the first time range flashes.
10. Select the end of the first time range by turning the .

Note
Select the value --:-- in order not to program a first time range.

11. Confirm the value programmed by pressing the .

Fig. 118 Selecting the time range end time of parameter 1st Time OFF

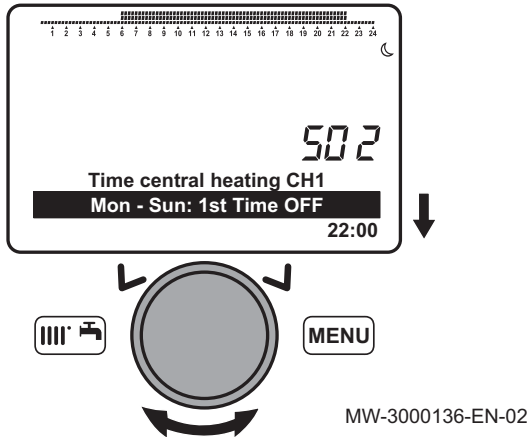
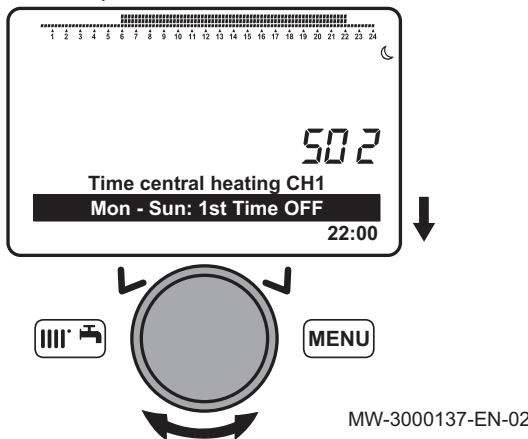

Fig. 119 Selecting the time range end time of parameter 1st Time OFF



12. Select the parameter **1st Time OFF** (502, 522, 542 or 562) by turning the button.

- 13. Confirm the menu selection by pressing the button. The current selection flashes.
- 14. Select the beginning of the first time range by turning the button.
- 15. Confirm the value programmed by pressing the button.
- 16. Repeat the programming for the second and third time ranges.

Tab.54 Parameters of the time ranges

	First time range	Second time range	Third time range
Beginning of the time range	- 1st Time ON (501, 521, 541 or 561)	- 2nd Time ON (503, 523, 543 or 563)	3rd Time ON (505, 525, 545 or 565)
End of the time range	1st Time OFF (502, 522, 542 or 562)	2nd Time OFF (504, 524, 544 or 564)	3rd Time OFF (506, 526, 546 or 566)

Note
Press the key to return to the main screen.

For more information, see
Changing the operating mode, page 77
Selecting a heating circuit, page 85
Default time ranges, page 88
Copying a time range, page 92

■ **Copying a time range**

Note
It is possible to copy a time range from one day to another. It is not possible to copy a time range from a period of several days.

- 1. Select a heating circuit.
- 2. Press the key to access the parameters.

Fig. 120 Selecting the menu Time central heating CH1

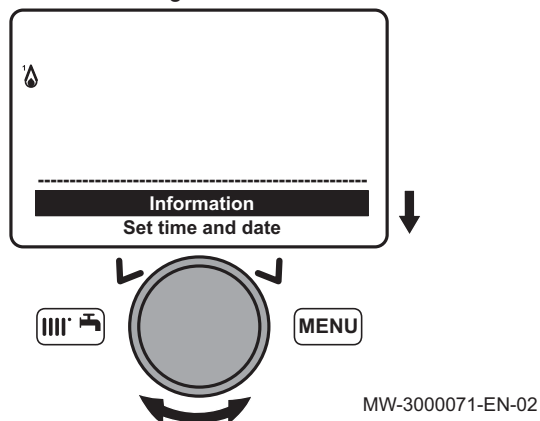

Fig. 121 Selecting the parameter Select days

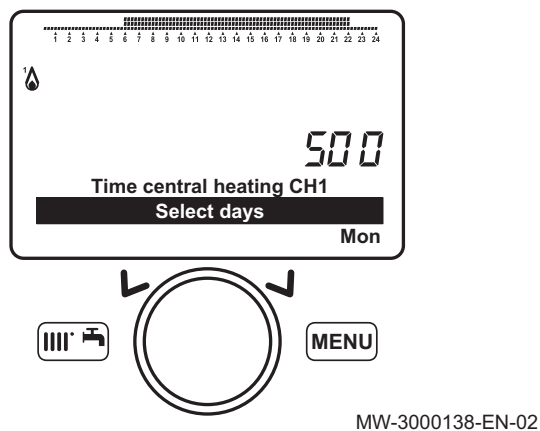
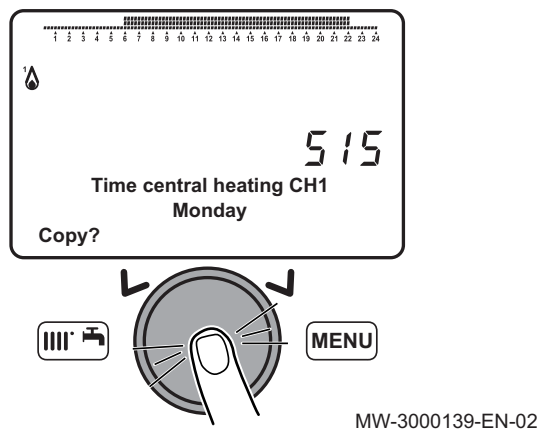

Fig. 122 Confirming the menu selected



3. Select the **Time central heating CH1** menu by turning the button.



Note

- For heating circuits 2 and 3, select the parameters **Time central heating CH2** or **Time setting 3/CHP**.
- For the domestic hot water circuit, select the parameter **Time hot water**.

4. Confirm the menu selection by pressing the button . The parameter **Select days** (500, 520, 540 or 560) appears.

5. Confirm the menu selection by pressing the button . The current selection flashes.

6. Select a day.

7. Confirm the menu selection by pressing the button .

8. Select a predefined or customised time range.

9. Select the parameter **Copy?** (515, 535, 555 or 575) by turning the button.

10. Confirm the menu selection by pressing the button . The parameter **Copy to** appears.

Fig. 123 Selecting the parameter Copy to

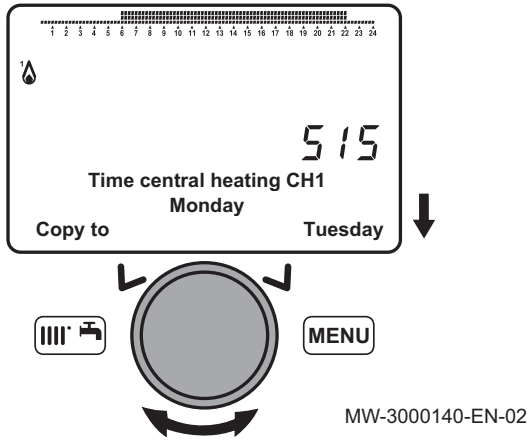

11. Select a target day by turning the button.
12. Confirm the menu selection by pressing the button .

Note

- Repeat the copy to other days if necessary.
- Press the key to return to the main screen.

For more information, see

- Changing the operating mode, page 77
- Selecting a heating circuit, page 85
- Selecting a Timer Program, page 89
- Customising the time ranges, page 90

■ **Resetting the timer programs to zero**

1. Press the key to access the parameters.
2. Select the **Time central heating CH1** menu by turning the button.

- Note**
- For heating circuits 2 and 3, select the parameters **Time central heating CH2** or **Time setting 3/CHP**.
 - For the domestic hot water circuit, select the parameter **Time hot water**.
3. Confirm the menu selection by pressing the button . The parameter **Select days** (500, 520, 540 or 560) appears.

Fig. 124 Selecting the menu Time central heating CH1

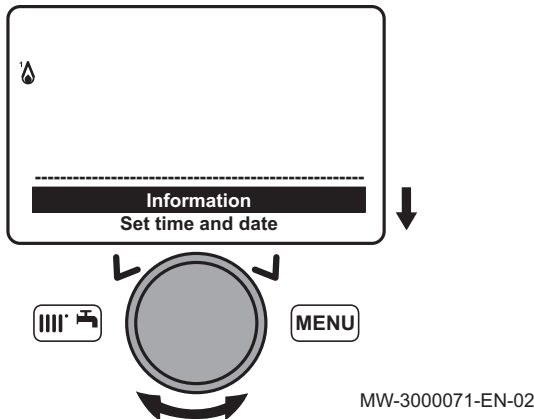
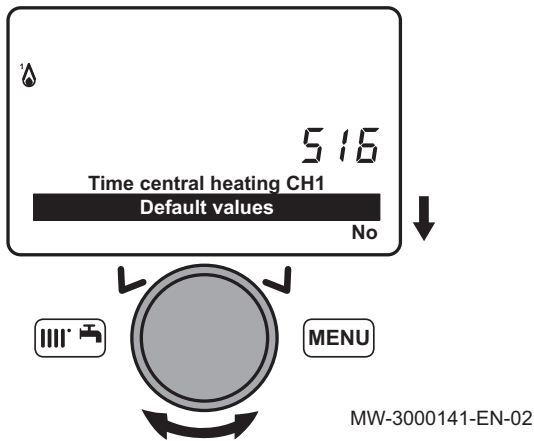
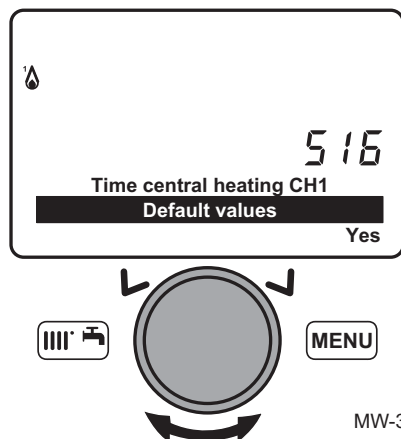

Fig. 125 Selecting the parameter Default values



4. Select the parameter **Default values** (516, 536, 556 or 576) by turning the button.
5. Confirm the parameter selection by pressing the button. The parameter **No** flashes.

Fig. 126 Selecting the parameter Yes



MW-3000142-EN-02

6. Select the parameter **Yes** by turning the button.
7. Confirm the parameter selection by pressing the button.



Note
Press the key to return to the main screen.

The reset to zero of the timer program is effective.

Fig. 127 Confirming the selected temperature

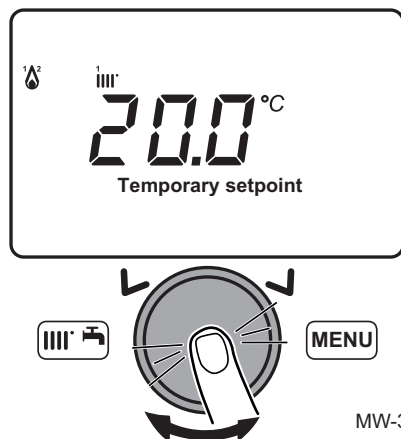

MW-3000143-EN-02

1. From the control panel main screen, turn the button to increase or reduce the temperature value.
2. Confirm the menu selection by pressing the button .

9.2.14 Setting a temporary heating flow temperature

9.2.15 Managing boilers in cascade

Boilers in cascade are controlled and managed by the master boiler.

1. Set the following parameters on the master boiler:

Tab.55 Configuration cascade master boiler

Parameter number	Parameter	Setting	Description
3540	Auto source seq ch'over	Number of hours	Operating time before the automatic change of the master boiler sequence.
3541	Auto source seq exclusion	- First - First and last - Last - None	Exclusion of the boiler or boilers from the periodic sequence rotation.



For more information, see
List of installer parameters, page 64

9.3 Accessing the information menu

1. Go to the parameters menu by pressing the key.

Fig. 128 Selecting the menu Information

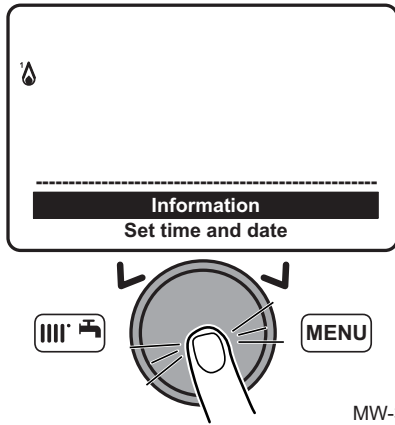

MW-300098-EN-02

Fig. 129 Selecting the various items of information

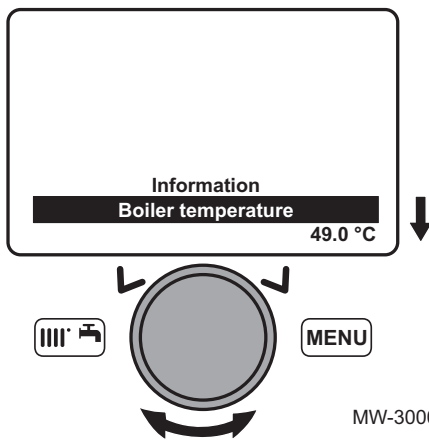

MW-300099-EN-02

2. Select the Information menu with the rotary button (⌚).
3. Confirm by pressing the rotary button (⌚).

4. Use the rotary button (⌚) to scroll through the various items of information.



For more information, see
Information menu, page 61

10 Maintenance

10.1 General

We recommend having the boiler inspected and serviced at regular intervals.

- Boiler maintenance and cleaning must be carried out at least once a year by a qualified professional.
- Have an inspection carried out and the flues swept **at least once a year** or more, depending on the regulations in force in your country.



Caution

Failure to service the appliance voids the warranty.



Caution

Maintenance work must be carried out by a qualified professional.



Caution

Only genuine spare parts may be used.

10.2 Standard inspection and maintenance operations

10.2.1 Performing the annual service

1. Check the outward appearance and tightness of the gaskets on the gas circuit and the combustion circuit.
2. Check for any impurities inside the combustion chamber. Use a vacuum cleaner for any cleaning work.
3. Check the condition of the insulation in the door and at the bottom of the combustion chamber and the condition of the gaskets on the combustion chamber door.
4. Check the condition and position of the ignition and flame detection electrodes, as well as the condition of the burner and its retaining device.
5. Check for any impurities inside the siphon.
6. Dry up as much as possible any water that may have stagnated in the bottom of the boiler as the result of a maintenance operation.
7. Check that there are no obstructions in the discharge and air intake pipes.
8. Check that the fan is working correctly.
9. Check the combustion and the correct calibration of the gas valve.
10. Check the pressure in the heating system.
11. Check the pressure in the expansion vessel.



For more information, see

Cleaning the heat exchanger, page 100

Checking the burner, page 100

Cleaning the siphon, page 102

Check the combustion, page 104

10.2.2 Removing the burner

1. Switch off the mains supply to the boiler.
2. Close the gas inlet valve.
3. Close the valves on the heating circuits.
4. Access the internal boiler components

Fig. 130 Removing the cables from the fan

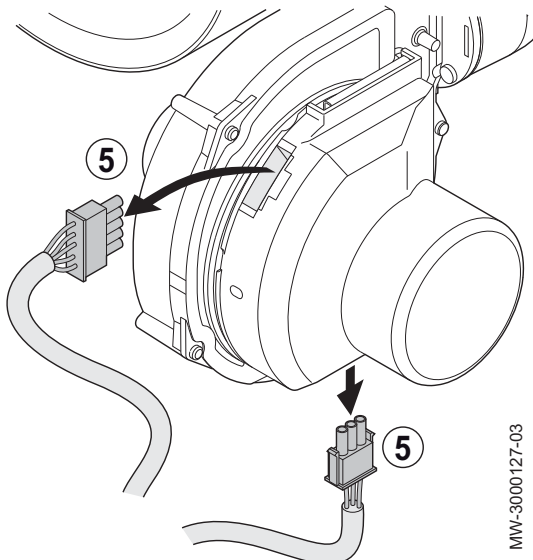

MW-3000127-03

5. Disconnect the power and command cables on the fan.

Fig. 131 Removing the cables from the electrode and the sensor

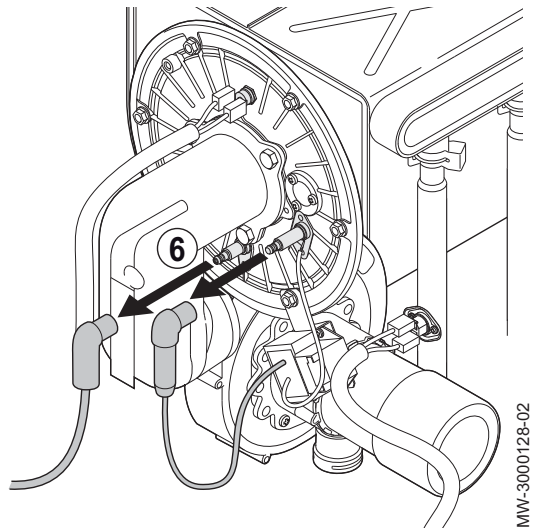

MW-3000128-02

6. Disconnect the ignition electrode and the flame detection sensor.

Fig. 132 Removing the connection pipe

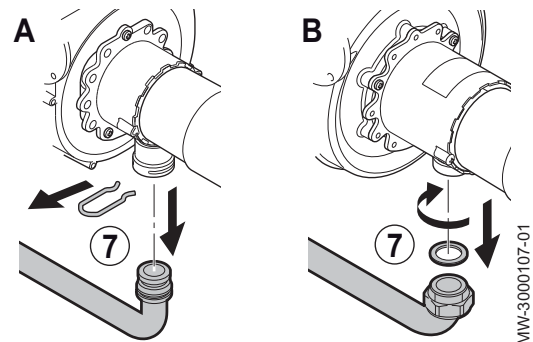

MW-3000107-01

7. Remove the pipe connecting the gas valve to the Venturi unit.

Reference	Model
A	POWER HT+ 1.50
B	POWER HT+ 1.70
	POWER HT+ 1.90
	POWER HT+ 1.110

Fig. 133 Disconnecting the safety thermostat on the combustion chamber door

8. Disconnect the 2 wires from the safety thermostat on the combustion chamber door and the pin under the ignition electrode.

and the pin under the ignition electrode

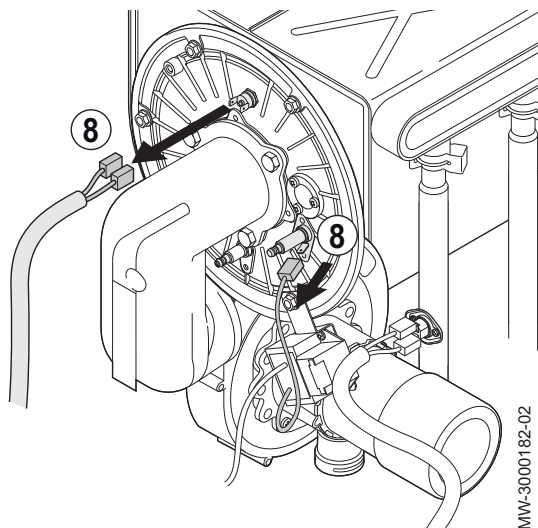

MW-3000182-02

Fig. 134 Removing the retaining nuts

9. Remove the nuts holding the burner in place on the heat exchanger.

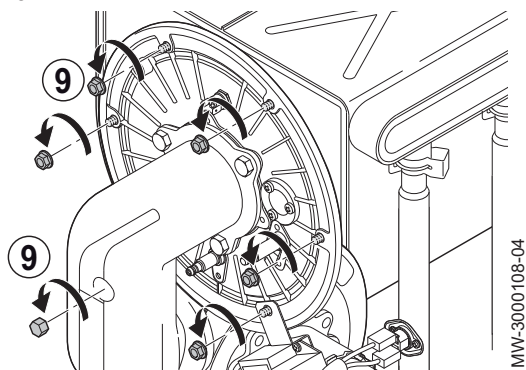

MW-3000108-04

Fig. 135 Removing the fan, the collector and the burner

10. Remove the fan, the Venturi and the burner to access the inside of the heat exchanger.

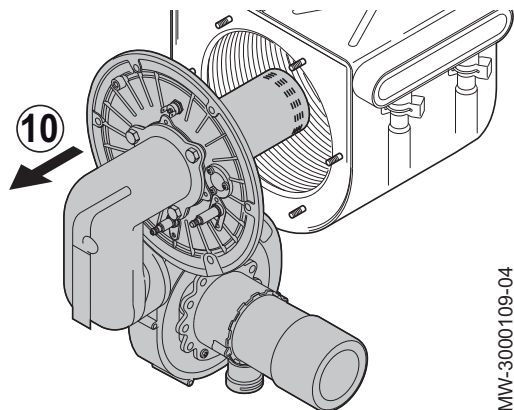

MW-3000109-04

Fig. 136 Burner

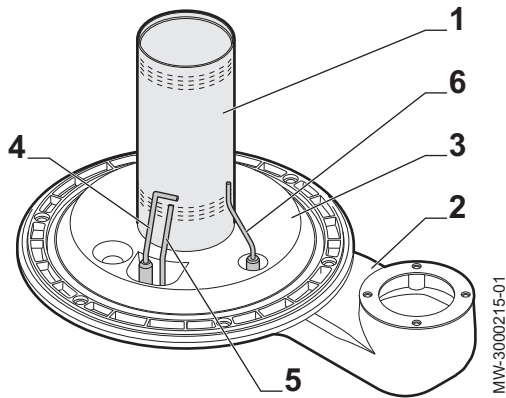

For more information, see Accessing the internal boiler components, page 35

■ Burner description

- 1 Burner
- 2 Air/gas collector
- 3 Insulating surface area
- 4 Ignition electrode
- 5 Earth electrode
- 6 Flame detection electrode

Fig. 137 Cleaning the exchanger

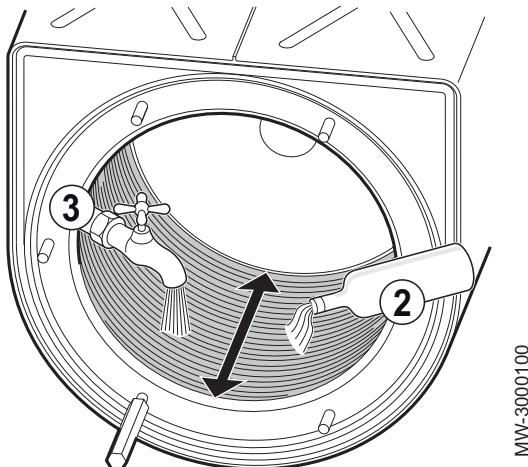
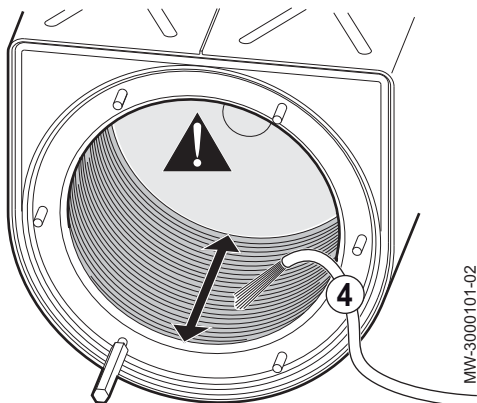

Fig. 138 Water jet cleaning



10.2.3 Cleaning the heat exchanger

1. Remove the burner.
2. Clean the pipes inside the heat exchanger using diluted white vinegar and a nylon brush.
3. Flush with water.

Note
The water will exit the heat exchanger by passing through the condensates discharge siphon.

4. After twenty minutes, wash off any dirt with a powerful water jet.

Caution
Do not use a high-pressure cleaner. Be careful not to direct the water jet straight at the insulating surface behind the heat exchanger. If the insulating surface is wet, it must be changed.

5. Check the burner.
6. Clean the siphon.
7. Remount the burner.

For more information, see
Removing the burner, page 97
Checking the burner, page 100
Cleaning the siphon, page 102
Remounting the burner, page 102

10.2.4 Checking the burner

1. Remove the burner.
2. Check whether the surface of the burner is damaged in any way. Replace the burner and its gasket if they are damaged.

Fig. 139 Distances and tolerances to be observed for the flame detection electrode and the burner

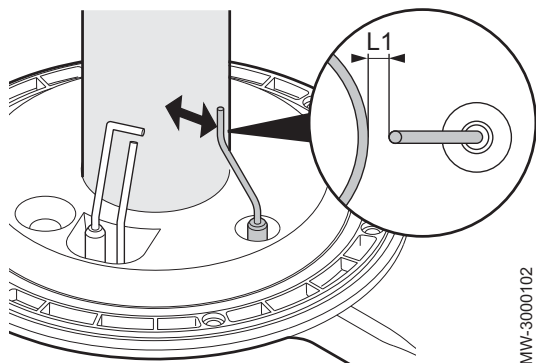

MW-3000102

Fig. 140 Distances and tolerances to be observed for the ignition electrode and the burner

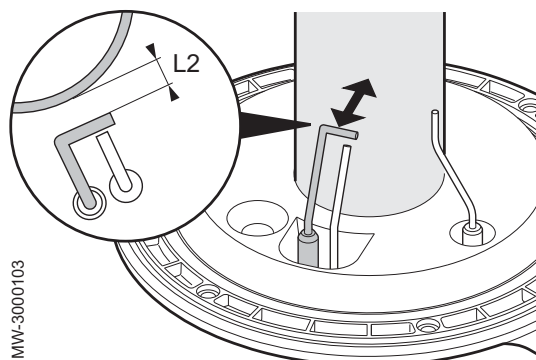

MW-3000103

Fig. 141 Distances and tolerances to be observed for the ignition electrode and the ground electrode

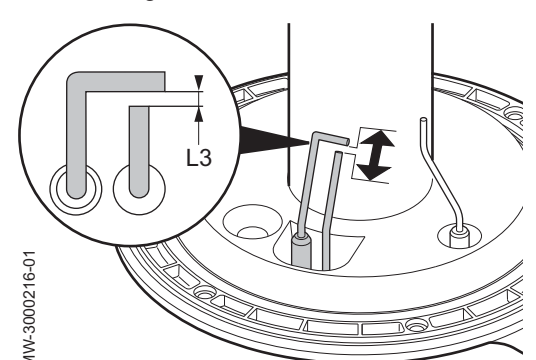

MW-3000216-01

Distance	POWER HT+ 1.50, POWER HT+ 1.70, POWER HT+ 1.90, POWER HT+ 1.110
L3	4 mm with a tolerance of +/- 0.5 mm

3. Check the safety thermostats.

i Note
Replace the safety thermostats if they are damaged.

4. Clean the burner with a vacuum cleaner.

i Note
Do not use a brush as it may damage the burner.

5. Check the distance between the flame detection electrode and the burner.

Tab.56 Distances and tolerances to be observed for the flame detection electrode and the burner

Dis tan ce	POWER HT+ 1.50, POWER HT+ 1.70, POWER HT+ 1.90	POWER HT+ 1.110
L1	7.5 mm with a tolerance of +/- 1 mm	5 mm with a tolerance of +/- 1 mm

i Note
Replace the flame detection electrode if it is damaged.

6. Check the distance between the ignition electrode and the burner.

Tab.57 Distances and tolerances to be observed for the ignition electrode and the burner

Dis tan ce	POWER HT+ 1.50, POWER HT+ 1.70, POWER HT+ 1.90	POWER HT+ 1.110
L2	10 mm with a tolerance of +/- 1 mm	7.5 mm with a tolerance of +/- 1 mm

i Note
Replace the ignition electrode if it is damaged.

7. Check the distance between the ignition electrode and the ground electrode.

Tab.58 Distances and tolerances to be observed for the ignition electrode and the ground electrode

i Note
Replace the ignition electrode if it is damaged.

8. Check whether the insulation on the inside surface of the burner is damaged in any way. The surface must be clean and free of any damage. Replace the insulation if it is damaged.

9. Remount the burner.

Fig. 142 Removing the siphon

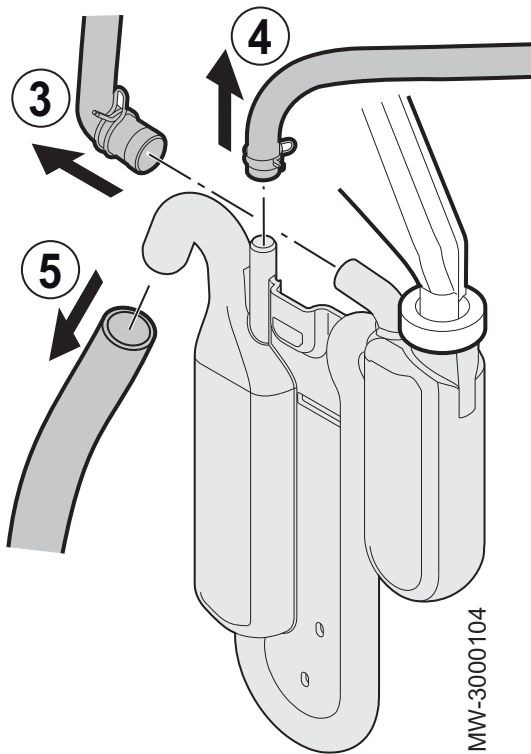

For more information, see

Removing the burner, page 97

Remounting the burner, page 102

10.2.5 Cleaning the siphon

1. Remove the burner.
2. Access the siphon.
3. Disconnect the pipe coming from the combustion chamber (POWER HT+ 1.50 and POWER HT+ 1.70 only).
4. Disconnect the pipe from the flue gas exchanger.
5. Disconnect the condensates discharge pipe.



Note

Use a pair of pliers to remove the spring tightening clamps.

6. Remove the siphon from the heating body by taking out the retaining screw with a cross-head screwdriver.
7. Clean the bottom of the siphon with water.
8. Completely fill the siphon.



Danger

Fill the siphon to the top. If the siphon is empty, there is a danger of intoxication by exhaust gases.

9. Put the siphon back on the heating body and put the retaining screw back in place with a cross-head screwdriver.
10. Reconnect the pipe from the combustion chamber, the pipe from the flue gas exchanger and, finally, the condensates discharge pipe.



Note

Use a pair of pliers to put the spring tightening clamps back in place.

11. Remount the burner.



For more information, see

Removing the burner, page 97

Accessing the internal boiler components, page 35

Remounting the burner, page 102

10.2.6 Remounting the burner

1. Remount the pipe connecting the gas valve to the Venturi unit.
2. Remount the burner, the Venturi and the fan.



Caution

Respect the torque on the burner fastening nuts: 5 N.m +/- 0.5.



Caution

Always use a new tightness gasket to reconnect the gas supply.

3. Reconnect the ignition electrode, the safety thermostat on the combustion chamber door and the flame detection sensor.



Note

Do not forget to remount the igniter on the burner.

4. Open all valves.
5. Check the tightness of the burner using a leak detection spray.
6. Put the covers back in place on the boiler.



Note

For the POWER HT+ 1.50 and POWER HT+ 1.70 models, put the panel located in front of the burner back in place.

7. Reconnect the earth wire.
8. Re-commission the boiler.



For more information, see
Commissioning procedure, page 54

10.2.7 Thermal fuse in the heat exchanger

The thermal fuse is located in the rear part of the heat exchanger and is connected in series to the safety thermostat. The function of the thermal fuse is to ensure the protection of the heat exchanger against the danger of overheating if the insulation malfunctions. Intervention by the device is signalled by the display of the anomaly **E110** on the screen.

- 1 Rear of the heat exchanger
- 2 Thermal fuse

Fig. Location of the thermal fuse
143

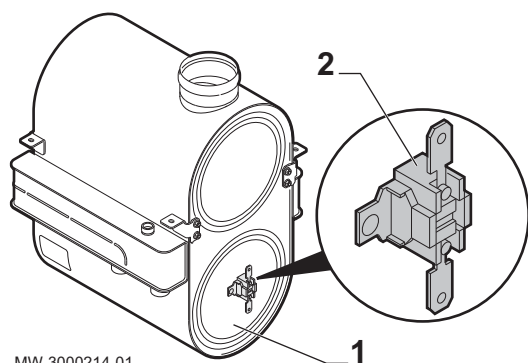

MW-3000214-01

**Note**

When replacing the thermal fuse, also replace the insulating surface (inside the heat exchanger) which has been damaged by overheating.

**For more information, see**

Removing the burner, page 97

Fig. 144 Connecting the flue gas analyser

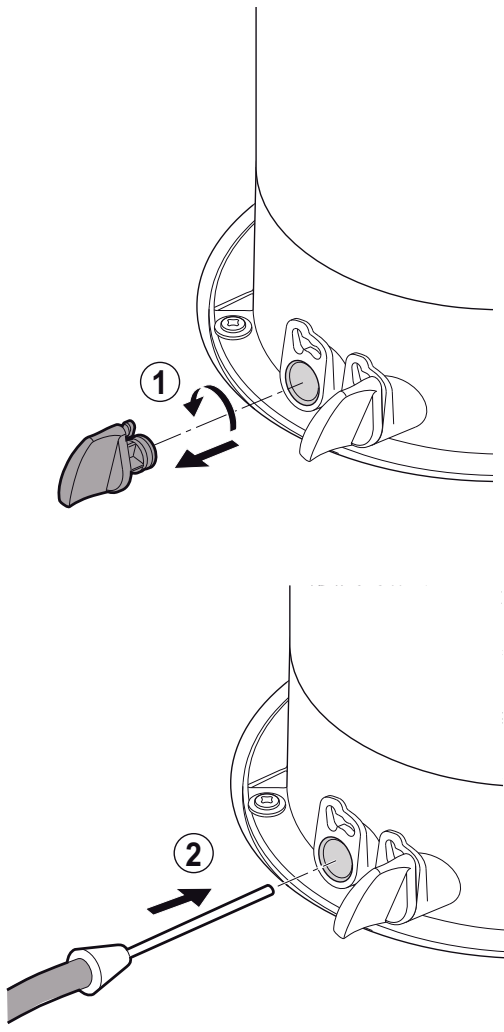

MW-3000110-03

10.2.8 Check the combustion

■ Checking combustion (maximum heat input)

1. Unscrew the plug in the flue gas measurement point.
2. Connect the flue gas analyser.

**Note**

- Ensure that the opening around the sensor is completely sealed when taking measurements.
- Insert the sensor into the flue gas measurement point to at least 8 cm for POWER HT+ 1.50 and POWER HT+ 1.70.
- Insert the sensor into the flue gas measurement point to at least 9 cm for POWER HT+ 1.90 and POWER HT+ 1.110.

3. Set the boiler's heat input to 100%.
4. Measure the percentage of CO₂ in the flue gases.
5. Compare the values measured with the set point values in the Control and setting values table.

**Note**

A tolerance of +/- 0.5% is acceptable when the front panel is closed.

6. If necessary, modify the air/gas ratio.

Fig. 145 Checking the air in the intake circuit

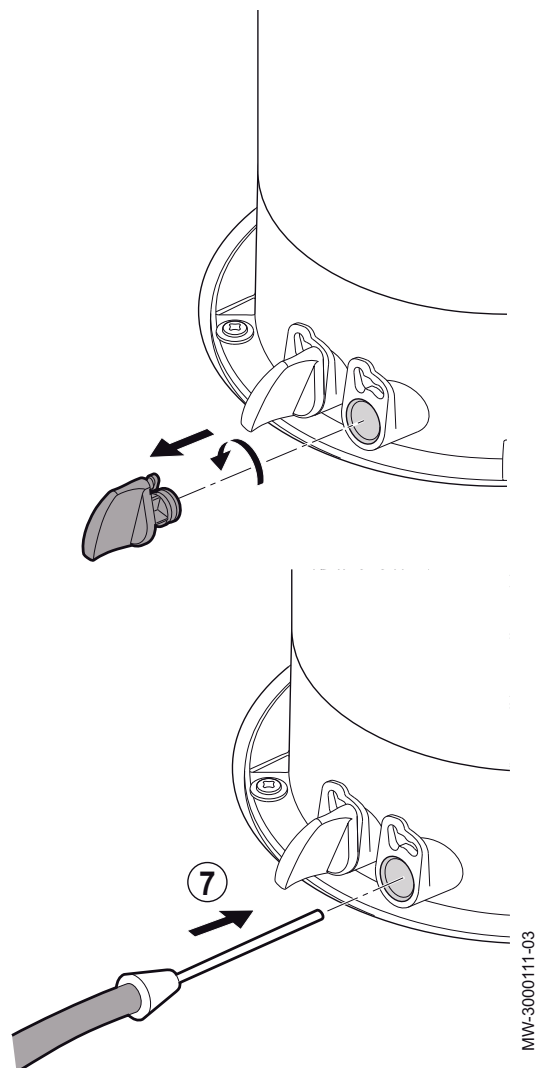

7. If necessary, check the return into circulation of any combustion products if using coaxial pipes. The sensor will then be connected to the outlet connected to the combustion air intake circuit.

**For more information, see**

Using the boiler according to thermal output, page 84
 CO₂ checking and setting values, page 0
 Checking combustion (reduced heat input), page 106

Fig. 146 Connecting the flue gas analyser

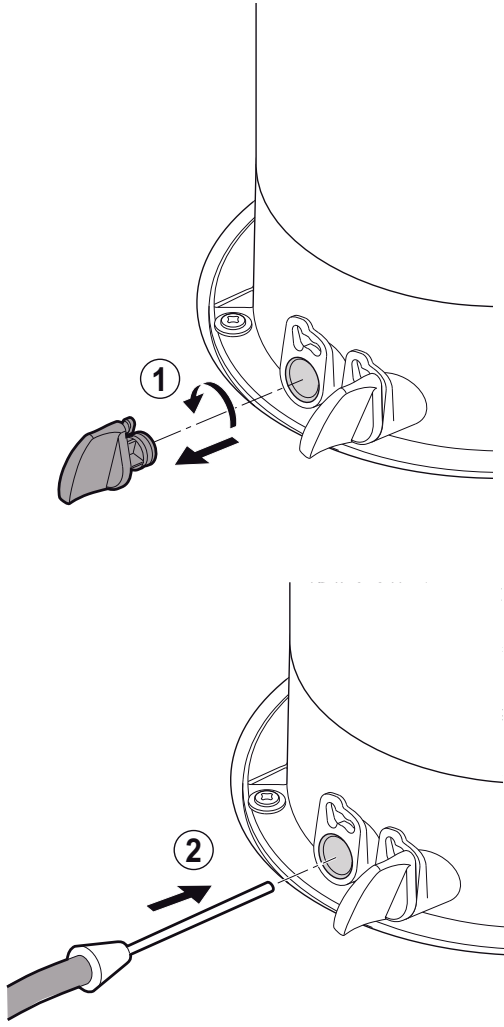

■ Checking combustion (reduced heat input)

1. Unscrew the plug in the flue gas measurement point.
2. Connect the flue gas analyser.

**Note**

- Ensure that the opening around the sensor is completely sealed when taking measurements.
 - Insert the sensor into the flue gas measurement point to at least 8 cm for POWER HT+ 1.50 and POWER HT+ 1.70.
 - Insert the sensor into the flue gas measurement point to at least 9 cm for POWER HT+ 1.90 and POWER HT+ 1.110.
3. Set the boiler's heat input to 0%.
 4. Measure the percentage of CO₂ in the flue gases.
 5. Compare the values measured with the set point values in the Control and setting values table.

**Note**

- A tolerance of +/- 0.5% is acceptable when the front panel is closed.
6. If necessary, modify the air/gas ratio.

Fig. 147 Checking the air in the intake circuit

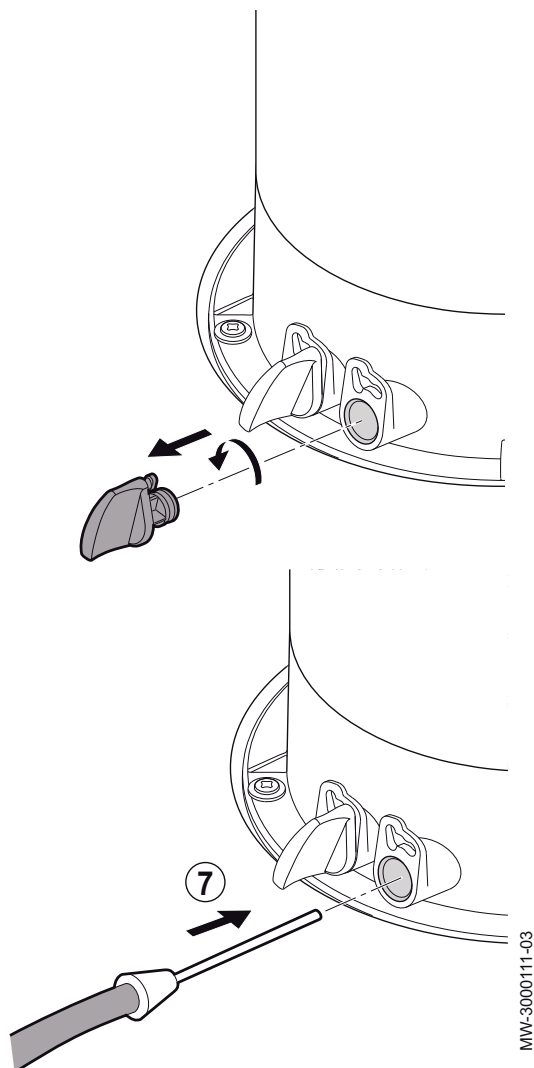

7. If necessary, check the return into circulation of any combustion products if using coaxial pipes. The sensor will then be connected to the outlet connected to the combustion air intake circuit.



For more information, see

- Using the boiler according to thermal output, page 84
- CO₂ checking and setting values, page 0
- Setting the air/gas ratio (maximum heat input), page 0

10.3 Replacing the 4 A fuses on the electrical terminal blocks



Danger of electric shock

Before any work, switch off the mains supply to the boiler.

Fig. 148 Location of the fuse holder

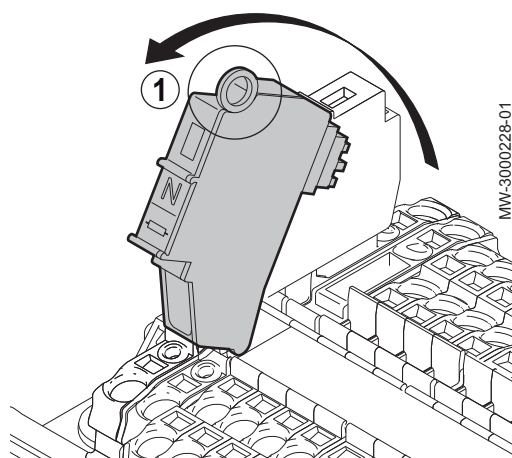

1. Pivot the fuse-holder socket **N** towards you.

Fig. 149 Location of the fuse

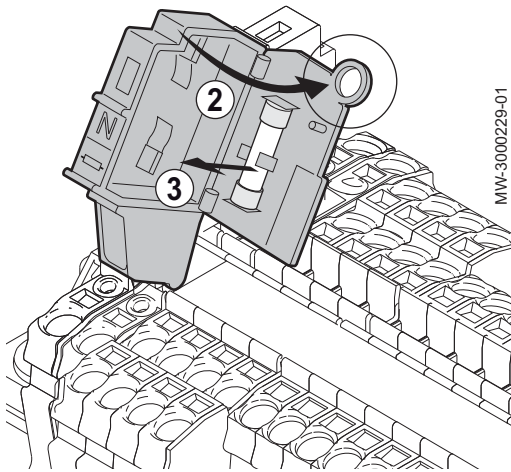

2. Open the fuse-holder socket with the eyelet.
3. Take out the damaged fuse and replace it with an identical one (4 A).
4. Check the fuse L, proceeding in the same way.

11 Troubleshooting

11.1 Error codes

Fig. 150 Error code

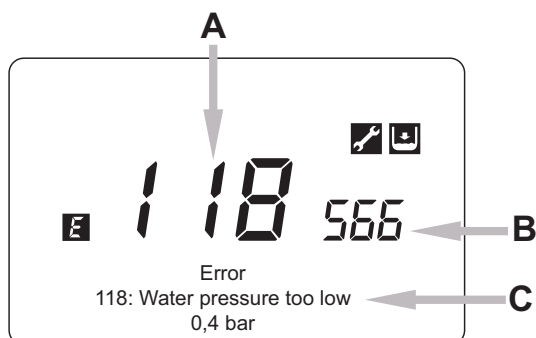

- A Error code
 B Secondary error code
 C Description of the error



Note

Press the key to return to the main display.

- The **E** symbol continues to be displayed on the control panel.
- If the error is not resolved after one minute, the error code is displayed on the control panel a second time.

Tab.59 List of error codes

BM-000026-GB-03

E	Display	Description of the error
20	20:Boiler sensor 1	Flow back sensor.
28	28:Flue gas temp sensor	Flue gas sensor.
40	40:Return sensor 1	Return temperature sensor.
46	46:Return sensor cascade	Cascade return temperature sensor error.
52	52:HW sensor 2	Solar domestic hot water sensor (if incorporating a solar system).
60	60:Room sensor 1	Room temperature sensor 1 error.
65	65:Room sensor 2	Room temperature sensor 2 error.
68	68:Room sensor 3	Room temperature sensor 3 error.
78	78:Water pressure sensor	Hydraulic pressure sensor error.
73	73:Collector sensor 1	Solar collector sensor (if incorporating a solar system).
83	83:BSB short-circuit	Communication problem between boiler PCB and control unit. Probable short circuit on the heating.
84	84:BSB address collision	Address conflict between several control units (internal anomaly).
91	91:Data loss in EEPROM	Loss of data in EEPROM.
98	98:Extension module 1	Extension module 1 error.
99	99:Extension module 2	Extension module 2 error.
100	100:2 clock time masters	2 master clocks
102	102:Clock without backup	Master clock with no power reserve.
103	103:Communication failure	Communication error.
109	109:Boiler temp supervision	Air present in the boiler circuit (anomaly)
117	117:Water pressure too high	Pressure in hydraulic circuit too high.
118	118:Water pressure too low	Pressure in hydraulic circuit too low.
125	125:Boiler temp too high	Safety cut-off for absence of circulation (check made by a sensor).
128	128:Loss of flame in op	Flame extinguished.
130	130:Flue gas temp too high	Cut-off by flue gas sensor for overheating.
151	151:BMU internal	Internal error on heating PCB.
152	152:Parameterization	General parameter setting error.
153	153:Unit locked	Appliance locked manually.
160	160:Fan speed threshold	Fan operation error.
171	171:Alarm contact 1 active	ACI board error.

E	Display	Description of the error
178	178:Limit thermostat CH1	Safety thermostat CH1.
179	179:Limit thermostat CH2	Safety thermostat CH2.
321	321:HW outlet sensor	Domestic hot water sensor damaged.
343	343:Solar integration missing	General parameter setting error on the solar system (if incorporating a solar system).
353	353:Casc sens B10 missing	B10 cascade sensor missing.
372	372:Limit thermostat CH3	Safety thermostat CH3.
373	373:Extension module 3	Extension module 3.
384	384:Extraneous lighth	Light incorrect (parasite flame — internal anomaly).
385	385:Mains undervoltage	Power supply voltage too low.
386	386:Fan speed tolerance	Fan threshold speed not reached.
430	430:Dyn water pres too low	Safety cut-off for absence of circulation (check made by a pressure sensor).
432	432:Function ground missing	Earthing function not connected.



**Note**

This list is not exhaustive. Other error codes may be displayed. Contact the accredited technical assistance service.

**Note**

If the display of the error code persists, contact the accredited assistance service.

**Note**

If the error code simultaneously displays the  and  symbols, contact the accredited technical assistance service.

**For more information, see**

Cleaning the heat exchanger, page 100
 Standard inspection and maintenance operations, page 97
 Removing the burner, page 97
 Checking the burner, page 100
 Remounting the burner, page 102
 Thermal fuse in the heat exchanger, page 103
 Check the combustion, page 104
 Checking combustion (maximum heat input), page 104
 Checking combustion (reduced heat input), page 106

11.1.1 Automatic error code clearing

If the symbol  is displayed at the same time as the error code, the error code is automatically cleared when the cause that prompted it stops.



A flow or return temperature in excess of the critical value prompts an error code. The error code is automatically cleared when the temperature drops below the critical value.

**For more information, see**

- Cleaning the heat exchanger, page 100
- Standard inspection and maintenance operations, page 97
- Removing the burner, page 97
- Checking the burner, page 100
- Remounting the burner, page 102
- Thermal fuse in the heat exchanger, page 103
- Check the combustion, page 104
- Checking combustion (maximum heat input), page 104
- Checking combustion (reduced heat input), page 106

11.1.2 Clearing error codes

If the probable cause of an error code is resolved but the error code continues to be displayed, proceed as follows to clear the error code:

1. Press the  button.
The command **Reset? Yes** is displayed on the control panel.
2. Confirm by pressing the  button.
The error code disappears after a few seconds.

**For more information, see**

- Cleaning the heat exchanger, page 100
- Standard inspection and maintenance operations, page 97
- Removing the burner, page 97
- Checking the burner, page 100
- Remounting the burner, page 102
- Thermal fuse in the heat exchanger, page 103
- Check the combustion, page 104
- Checking combustion (maximum heat input), page 104
- Checking combustion (reduced heat input), page 106

12 Decommissioning

12.1 Decommissioning procedure



Warning

Only qualified professionals are authorised to work on the boiler and the heating installation.

To switch off the boiler temporarily or permanently, proceed as follows:

1. Switch off the boiler.
2. Cut the electrical power to the boiler.
3. Close the gas valve to the boiler.
4. Drain the central heating system or ensure frost protection.
5. Close the door of the boiler to prevent air circulating inside it.
6. Remove the pipe connecting the boiler to the chimney and close the nozzle with a plug.

12.2 Recommissioning procedure



Warning

Only qualified professionals are authorised to work on the boiler and the heating installation.

Should it prove necessary to carry out the recommissioning of the boiler, proceed as follows:

1. Re-establish electrical power to the boiler.
2. Remove the siphon.
3. Fill the siphon with water.
The siphon must be completely full.
4. Put the siphon back in place.
5. Fill the central heating system.
6. Start up the boiler.



For more information, see

Check-list before commissioning, page 54

13 Disposal/recycling

13.1 Disposal and Recycling

Fig. 151 Recycling



Warning

Removal and disposal of the boiler must be carried out by a qualified installer in accordance with local and national regulations.

If you need to remove the boiler, proceed as follows:

1. Switch off the boiler.
2. Cut the electrical power to the boiler.
3. Close the main gas valve.
4. Close the water mains.
5. Close the gas valve on the boiler.
6. Drain the installation.
7. Remove the air vent hose above the siphon.
8. Remove the siphon.
9. Remove the air/flue gas pipes.
10. Disconnect all pipes on the underside of the boiler.
11. Dismantle the boiler.

14 Appendix

14.1 EC Declaration of Conformity

The unit complies with the standard type described in the EC declaration of conformity. It has been manufactured and commissioned in accordance with European directives.

The original declaration of conformity is available from the manufacturer.

© Copyright

All technical and technological information contained in these technical instructions, as well as any drawings and technical descriptions supplied, remain our property and shall not be multiplied without our prior consent in writing. Subject to alterations.



PART OF BDR THERMEA

